

ROVERS

MAGAZINE



OVERLAND JOURNAL

The publication for environmentally responsible, worldwide vehicle-supported expedition and adventure travel.

NEVER MISS A SINGLE ADVENTURE



Subscribe

overlandjournal.com

explore your next experience

Land Rover Experience at Equinox Resort

80 Union Street Manchester Village, VT 05254

Open 7 days a week 802.362.0687



experience



ARB Winch Bull Bars

ARB Bull Bars features reinforced steel wrap around bumper with integral protection bar and built in recovery points. Includes mounting points for headlamp washers, CB aerial, recovery hitches, and driving lamps. Finished in a durable powder coated satin black, or you can paint to match your Land Rover. Built to facilitate a Warn 9,000 lb winch with roller fairlead (not included).

LR3 ARB Winch Bull Bar
3432150 \$ 1299.00

Discovery I ARB Winch Bull Bar
3432080 \$ 849.95

Discovery II ARB Winch Bull Bar, '99-2002
3432060 \$ 1299.00

Discovery II ARB Winch Bull Bar, 2003 on
3432120 \$ 1152.00

Discovery II ARB Sahara Winch Bull Bar, 2003 on
3932020 \$ 1199.00

Range Rover Classic ARB Winch Bull Bar
3430020 \$ 899.00

Defender ARB Winch Bull Bar
3432090 \$ 899.00
Adapter for USA Defender 110
RNA089 \$ 179.00

Please Note: Some features may differ between models.



Trust your dream fly-fishing trips to Orvis.

Whether you choose to fish in the U.S. or wish to travel to remote sections of the world, the fishing travel experts at Orvis have done the research for you.

Trust your trip to the world leader in fly fishing and fly-fishing travel. Whether you want a rustic and remote wilderness experience in Maine or Alaska or a luxurious, eco-savvy resort in the Seychelles, the Orvis Travel group has done the research, visited the property, and put the Orvis name behind your experience.

When you book with an Orvis-Endorsed Lodge or an Orvis International destination, you are assured of the finest experience possible in every aspect of service, accommodations, cuisine, and ultimately the fishing experience. We've been there so you can go there with confidence. **For more information please call 800 778 4778 or go to orvis.com/sportingover**

ORVIS®
Sporting Services



Classic.



Shop for all your Land Rover Parts at Roversnorth.com

- **NEW** International Shipping
- Land Rover Forum
- Clearance Outlet
- Factory News Blog
- Rovers Magazine
- Open 24/7
- Land Rover Vehicles
- Series II, IIA, III
- Defender 90, 110, 130
- Range Rover
- Discovery

Discovery Bonnet Blackout Kit

Essential for night time off-road driving safety, the Blackout Kit bonnet decal increases visibility by eliminating the glare from roof mounted driving lamps.

Discovery II Blackout Kit.....	PLH622	\$ 79.00
Discovery I Blackout Kit.....	PLH623	\$ 79.00
Land Rover Decal 16" x 8".....	RNF254	\$ 9.95

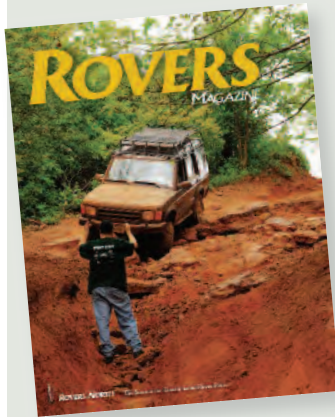

About the cover:

"The Royal Rovers" 2011 SCARR Rally event story and coverage inside from Texas begins on page 46.

Photo: Rovers North, SCARR Rally 2009.

Rovers Magazine is a publication of Rovers North, Inc.
Publisher: Mark Letorney
Art Director: Thompson Smith
Websites/Branding: Graham Letorney
Editor: Jeffrey Aronson
Contributing Editor: Tiffany Pfeiffer
 ©2011 Rovers North, Inc.
 This publication is written for the enjoyment of Rovers North customers and may not be reproduced without the express written permission of Rovers North Inc. While we at Rovers North make every effort to ensure accuracy within these pages, we are not to be held liable for typos and or omissions.
 Please be advised that all prices are subject to change without notice.

Rovers North Inc.
 1319 VT Route 128, Westford, Vermont 05494-9601, USA
 Sales: 1-800-403-7591
 Tech Line: (802) 879-0032
 Website: www.roversnorth.com
Hours: Mon-Fri: 8:00 - 6:00
 Sat: 8:30 - 12:30 EST
 Sightings submissions may be sent to our above address or email to sightings@roversnorth.com



Land Rover Discoverys "Running Deep In Arkansas" event coverage on page 42. Photo: Jim Edson.

Summer fun is attending a Land Rover club event.

Its a great way to enjoy your Land Rover, appreciate its unique capabilities, and to meet other enthusiasts. We always enjoy observing all the creative things done to Land Rovers. There are as many different types of enthusiasts as there are Land Rover models. All models lend themselves well to taking on a personality installed by their owners. We are particularly amazed at how many enthusiasts caught their bug after purchasing a new Land Rover. Suddenly one is not enough, and they find themselves an early Discovery or Defender to fix up for weekend adventures.

Adding accessories and mechanically improving an earlier Land Rover builds pride in ownership and enhances enthusiasts for the things that make Land Rovers such great vehicles. Sharing maintenance tips and explaining Land Rovers to customers is something everyone here at Rovers North enjoys daily.

From roof racks to skid plates we offer some of the best Land Rover accessories on the planet. With our experience supporting Land Rover fleets improving your Land Rover with quality parts and equipment becomes very informative, and cost effective.

Safety and component quality are the two aspects of improving Land Rover performance we always prioritize. At Rovers North we will spend the time with you to understand your requirements, and to recommend product that best match the way you use your Land Rover. Our goal is to promote a positive ownership experience, and for you to benefit from your investment in your Land Rover. We are a small family business that values your business and are committed to earning it.

Enjoy your Land Rover and have a great summer.

Andrea and Mark Letorney



Our mission is to support all original Land Rovers and older models that are no longer supported by your local Land Rover franchise. We offer the entire range of Land Rover Genuine Parts direct from Land Rover UK, providing the highest quality parts and accessories at the best prices. In addition we offer our own line of parts called ProLine. Sourced from a variety of manufacturers, ProLine is our alternative when a Genuine Part is no longer available or a lower cost replacement is preferred. Visit our website www.roversnorth.com for a more complete view of our selection, or call us. All new parts and accessories sold by Rovers North are covered by our one year unlimited mileage warranty. We invite you to experience our knowledge, experience and service. Thank you for choosing Rovers North.



TerraFirma
 Serious 4x4 Accessories

NEW TerraFirma Alloy Wheel

This super strong TerraFirma alloy wheel is rated at 1300kg per wheel and with the unique 'bead lock ready' outer rim (sold separately - RNA100L) providing incredible rock damage resistance and protection.
Fits: Defender, Discovery I, Range Rover Classic.
Alloy wheel, 7"x16", 20mm offset, anthracite, bead lock ready. RNA100A \$ 289.00 ea

NEW TerraFirma Bead Lock Kit

Set of 4 specially machined alloy rings designed to clamp the tire in place preventing it from being pushed off the rim at very low inflation pressures. The ring is machined in such a way that it centralises the tire on the wheel so that balancing is possible, something not usually achievable with other bead lock systems.

The bead lock ring kit also includes alignment dowels and a full set of allen key cap head bolts and lock nuts. The bead lock ring is recessed reducing rock damage to the bolt heads. The bead lock rings are powder coated anthracite grey with discreet TerraFirma logos. Also available as singles.
Bead Lock Kit Set of 4, anthracite RNA100L \$ 698.00



Letters to the Editor

Dear Rovers North,

I just read the article "14 Minutes of Fame" in the magazine and got quite cross. Jeffrey Aronson states there was no budget for a pair of license plates then describes the lavish lunch and dinner while "cos-tume and make-up artists poked and prodded". Having provided cars for many films and videos it's about time film makers provided a budget for the owners' cars. I bet the camera crew got paid! On a different note, excellent magazine. My '68 Air Portable is going great, the '93 Classic is soldiering on and the P38 is a gem.

Ben Chambers
Midway, GA

[Film production and catalogue companies do provide reimbursement for use of classic automobiles; for "14 Minutes," I wanted to do a favor for the director. We love your Land Rover collection – keep up the good work! –ed]

Dear Rovers North,

Last winter I was skiing and working at Stowe's Mountain Lodge Resort. This spring the gas guy in my town gave me this April's issue of your magazine. I flipped through it and saw a Range Rover I thought I'd seen before in Stowe. I'm pretty damn sure that '95 RRC flashed me while I was going down the mountain road after seeing my '94 Brooklands green County LWB. I bought my RRC from a guy's barn in Highgate, VT. It had been sitting there for four years with 98,000 miles on the clock and \$1400 bucks later, it was mine.

Alex Williams
Fisher's Island, NY

["It's a small world after all," as the song goes –ed]

Dear Rovers North,
MG's and Land Rover are my addiction. When I received an Eddie Bauer Friends special mailing, the photo of a Series Land Rover made my day. I got so excited I actually order something. Wow, the power of marketing!

Rodney Johnson
San Antonio, TX

[And that's why Land Rovers and MG's appear in catalogues –ed.]



Two lucky 2011 Arizona Land Rover Rally awards winners!

Right: Twins Elizabeth and Mary Lendvoyi, Portland, OR, were thrilled last winter when Portland finally received a substantial snowstorm. It made them even prouder knowing their parents, Michael and Lori Lendvoyi, are long time Land Rover enthusiasts.



NEW Land Rover Art

Enjoy some of the finest Land Rover Art available on prints, T-Shirts and mugs, only from Rovers North.

These illustrations are hand-crafted using old school techniques and medium with Rapidograph pens, prisma-color markers and lots of knowledge. Choose illustrations by our very own Art Director Thompson Smith using black and white pen & ink or full colour art by the talented Myles Murphy.

All art prints are sold exclusively through our CafePress Rovers North store at <http://www.cafepress.com/roversnorth>



To Order Land Rover Art
www.cafepress.com/roversnorth

NEW Defender 110 NAS Station Wagon Expedition



NEW Range Rover Classic Expedition

Defender 90 NAS Station Wagon



Product Features

- 23** Waxoyl, Tailgate Lids, KBX Grilles
- 26, 27** Mammoth Chequerplate body protection, Terraforma accessories
- 31** Hi-Lift Jacks, Recovery Accessories, Land Rover Art
- 34-37** Shocks, Coils, Springs, Suspension
- 54-58** Exmoor Trim, Seats, Interior Accessories & Defender A/C, Dash
- 59** Rubber Floor Mats, Soft Tops

TECHNICAL INFO & PARTS LISTINGS

- 24, 25** Mud Flaps, Window Regulators, Window Motors, Seat Belts
- 32, 33** Chassis, Repair & Footwell Parts
- 48-53** Replacement Parts
- 60, 61** Canvas Tops, Hoop Sets, Parts
- 62, 63** Tire Covers, Mirrors, Door Hinges
- 64-67** Clutch, Drum Brakes, Disc Brakes
- 68-76** Cooling Systems, Radiators, Hoses
- 77** Lights - Series, Defender, Discovery II

Background photo: Cool, beautiful and breathtaking Moraine Lake, Banff National Park, BC. Follow the Sailer's on their travels through western Canada, starting on page 6. Photo: Alexandra Sailer

Editorial Contents

- 4** Letters to the Editor
- 21** Behind The Steering Wheel
Jeffrey Aronson
- 28** Burke's Corner
Bill Burke



WESTWARD HO! Part Deux

Text: Alexandra Sailer
Photos: Steffan and Alexandra Sailer

Pg. 6



1/8 Scale Land Rover Series II

Text: Kevin Girling
Photos: Kevin Girling, Laurent Pierson

Pg. 16



Doctor's Orders

Text: Anne Stearns
Photos: Maria Carey

Pg. 38



Running Deep in Arkansas

Text, Photos: Jim Edson

Pg. 42



Travelling Like It's 1964

Text: John Moody

Pg. 44



The Royal Rovers

Text, Photos: Jim Edson

Pg. 46

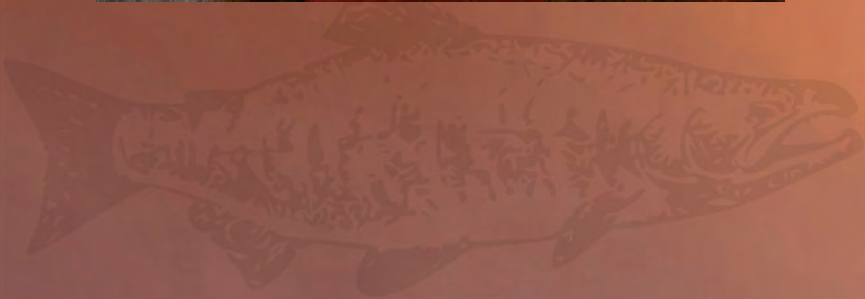

WESTWARD HO!

PART DEUX

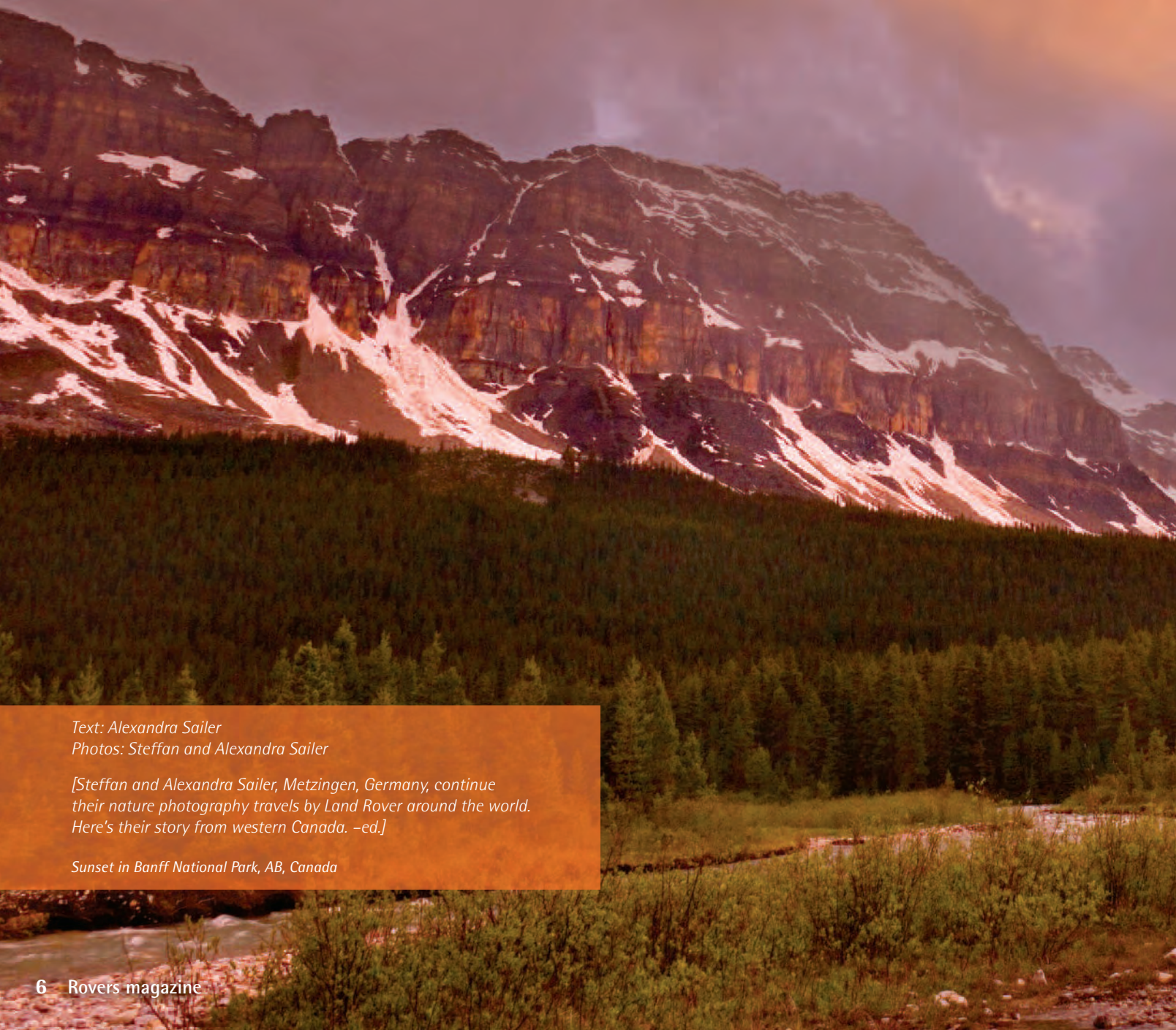

*Text: Alexandra Sailer
Photos: Steffan and Alexandra Sailer*

[Steffan and Alexandra Sailer, Metzingen, Germany, continue their nature photography travels by Land Rover around the world. Here's their story from western Canada. -ed.]

Sunset in Banff National Park, AB, Canada

“

Since Banff is famous for its huge numbers of wildlife, we spent the next days driving slowly up and down Bow Valley Parkway on the lookout for animals.

”



*Above top to bottom:
British Columbia Columbine
in full bloom; Grizzly Bear;
Columbia Ground Squirrels
sharing a moment.*

*Background: Majestic view
of Moraine Lake and the
Valley of the Ten Peaks.*



As we entered Canada through British Columbia we experienced the majesty of the Monashee Mountains on our way eastward towards the Rockies. We saw rivers and lakes with green glacier water surrounded by snow-capped mountains. Colourful blooming wildflowers along the roadside provided for additional variety. When we arrived in Yoho National Park, we took a walk around Emerald Lake and promptly saw our first moose grazing along the lakeshore. We also saw a lot of wildflowers like western columbine and several kinds of lady slippers. Then we headed towards Banff National Park. We made camp in one of the rather expensive campgrounds of the park and set off exploring. First, we visited breathtaking Moraine Lake, the Valley of the Ten Peaks and famous Lake Louise.

With Banff's fame as a wildlife habitat we spent a few days driving slowly up and down Bow Valley Parkway. We photographed black bears, grizzly bears, black-tailed deer, elk and also mountain sheep. Bears seemed drawn to the roadsides where their favourite delicacy, dandelions, grow in abundance.



*Above top to bottom:
Mountain Goat; Jasper
National Park; Big Horn
Sheep causing traffic
chaos on Sunwapta Pass.*

*Background: Roaming
Coyote on the prowl.*

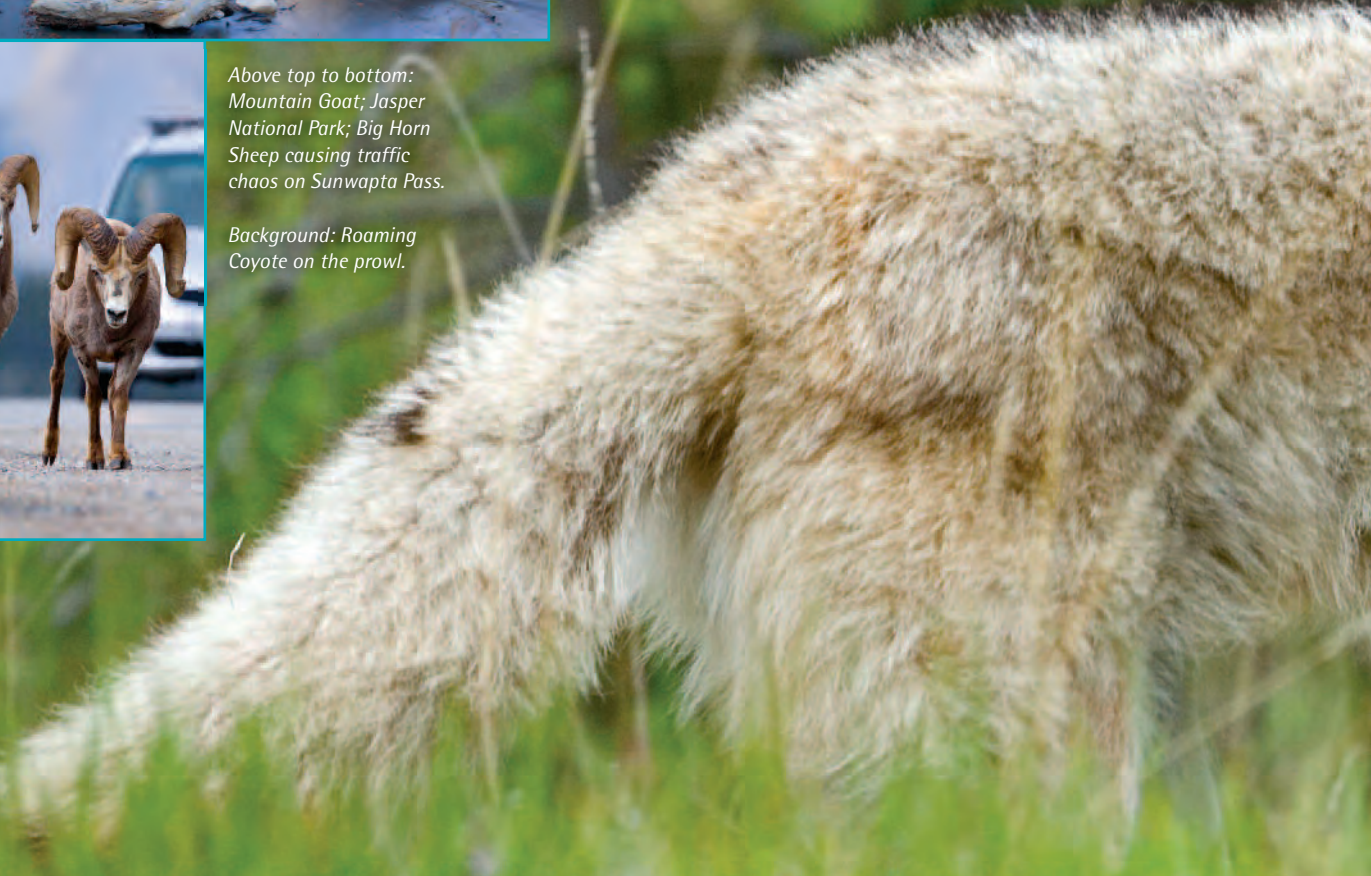



Travelling around the world you're bound to run into some medical problems and my turn came here in Banff, where my swollen leg turned out to be an allergic reaction. Fortunately, we ran into a young family from South Africa also touring the world. One member, Gary, turned out to be a physician and he had some medication that reduced my swelling—and my anxiety—considerably.

Happy, to be back on the road again, we left Banff and continued north to Jasper National Park. Shortly after entering Jasper National Park at Sunwapta Pass, we came upon a roadblock—caused by Bighorn Sheep. A few rams took a walk on the highway and couldn't be disturbed by anything. In the cliffs we also saw females with young running about.

We had a short look at Columbia Icefield and drove further north along the Athabasca River until we reached Jasper. There we camped and tromped about in the rain searching out more bears, coyotes and mountain goats. After 20 days in the Canadian Rockies with mostly rainy weather, we headed out of Jasper to the west on Yellowhead Highway through Mt. Robson Provincial Park and finally headed into Smithers.

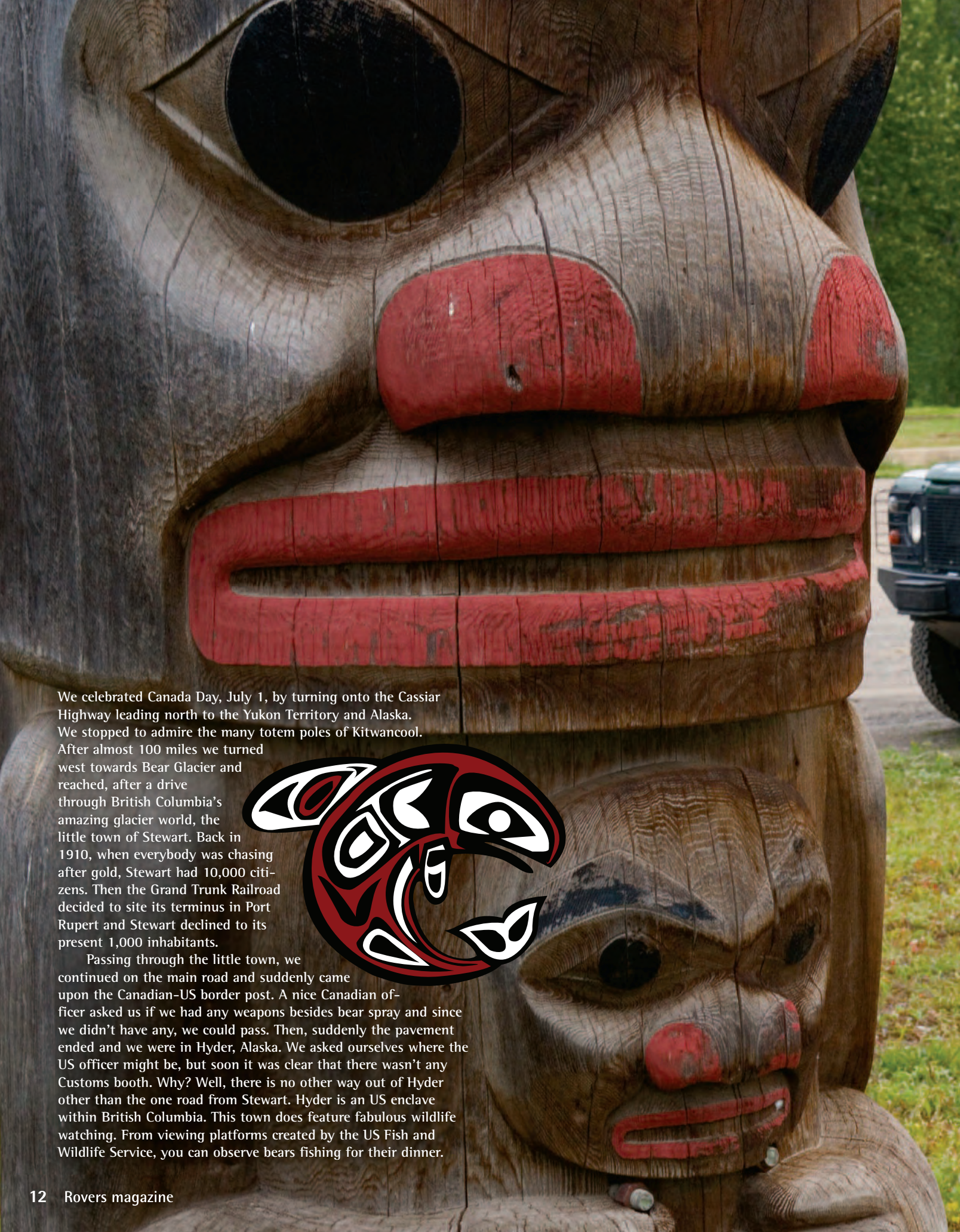

We celebrated Canada Day, July 1, by turning onto the Cassiar Highway leading north to the Yukon Territory and Alaska. We stopped to admire the many totem poles of Kitwancool. After almost 100 miles we turned west towards Bear Glacier and reached, after a drive through British Columbia's amazing glacier world, the little town of Stewart. Back in 1910, when everybody was chasing after gold, Stewart had 10,000 citizens. Then the Grand Trunk Railroad decided to site its terminus in Port Rupert and Stewart declined to its present 1,000 inhabitants.

Passing through the little town, we continued on the main road and suddenly came upon the Canadian-US border post. A nice Canadian officer asked us if we had any weapons besides bear spray and since we didn't have any, we could pass. Then, suddenly the pavement ended and we were in Hyder, Alaska. We asked ourselves where the US officer might be, but soon it was clear that there wasn't any Customs booth. Why? Well, there is no other way out of Hyder other than the one road from Stewart. Hyder is an US enclave within British Columbia. This town does feature fabulous wildlife watching. From viewing platforms created by the US Fish and Wildlife Service, you can observe bears fishing for their dinner.





Below left to right: Alert Black Bear; Grizzly Bear waiting for a big fat Salmon; Steffan Sailer, Photographer and Land Rover Defender 110 owner.



Background: Taking a break in Gitanyow with a cool totem pole.

LIMIT
20

HYDER
Townsite Limits

ENTERING
ALASKA

SPEED
LIMIT
20

SALMON GLACIER
SELF-GUIDED AUTO TOUR
3
Hyder
Alaska
State of Alaska
District of Stewart



Top: Salmon Glacier at sunset; Snow reins supreme on the Salmon Glacier road; Left: "Mira" the Grizzly Bear.



Hyder Inlet Road
RESTAURANT / RESERVATIONS
Boundary
Gallery
SAND
CATERING
FUDGE
AS FRESH
AS THE LADY
WHOMAKES IT

Welcome To... **HYDER, ALASKA**



We drove off towards Salmon Glacier, BC, enjoying the province's largest glacier fields. Even in July we saw lots of snow piled up alongside the road and atop the glacier.

After breakfast, we headed down the road again for another visit to the bear-viewing platform. We walked up and down the walkways and stared at the water. If we could spot the first salmon of the year, bears looking to feed would surely follow. At dawn the next day, we set up our photography gear and waited for more salmon to swim by and grizzly bears to come fishing. Will we see a catch? Will there be cubs? To find out, we had no other possibility than sit and wait—and so will you, dear reader.

Left: Alexandria Sailer taking in Salmon Glacier, BC just before sunset.



“Then, suddenly the pavement ended and we were in Hyder, Alaska”

This Series II will cost you the same as a fully restored original but it was not built in Solihull. Kevin Girling, International Correspondent for Land Rover World magazine went to find out more!

Having seen a photograph of this beautiful replication of a 1964 Series II, I was anxious to see it for myself. However, this involved a trip to Europe, to the village of Cusset close to Clermont Ferrand, a town almost at the very center of France to visit Laurent Pierson, a Land Rover owner and enthusiast.

Laurent's passion for Land Rovers began at a very young age. His father worked in Africa in the late 60's and is one of the relatively few Land Rover owners in the world to have actually crossed the Sahara Desert in a SWB Series II, on the way from Mali to Paris. On his return home to France at the end of his military service he purchased a 109 in order to provide transport for his family. Laurent was just 3-years-old when he saw his first Land Rover, an event that clearly influenced future vehicle purchases.

“Laurent was just 3 years old when he saw his first Land Rover”

At age 18, Laurent got his driver's license and learned to drive the 109. When he met Mary, his future wife, in 1997, it took him just six months to persuade her that her Renault really had to go. They purchased a 1964 Series II, which they still have to this day, and Mary used it as her daily drive for about a year before it was shipped to Corsica for vacations, an area ideal for a Land Rover. Corsica offers miles and miles of isolated dusty roads skirting deserted sandy beaches, which in turn provide seclusion and a dream vacation away from the madding crowd. The mechanical simplicity and capabilities of the Land Rover make it the perfect choice for such an adventure.



*Text: Kevin Girling
Photos: Kevin Girling, Laurent Pierson.
[Kevin Girling is the International Correspondent for Land Rover World magazine, a UK based Land Rover magazine published monthly. -ed.]*



1/8 Scale Land Rover Series II



'1/8th scale version of the steering box assembled exactly as the original produces the same play'



1/8 Scale Land Rover Series II

Laurent and Mary also shipped the vehicle to the French island of Gadeloupe in the Leeward Islands, off the north coast of South America. This was a trip they repeated later using their 2006 TD5 110, since by this time two children, Pauline and Charlyne, had arrived so the bigger vehicle was a necessity.

'He also needed good reference material and for this he turned to Rovers North.'

Laurent had enjoyed building model cars and boats since the early age of 8, and 5 years ago he decided to combine his engineering and modeling skills and produce a high-end scale model. The Series II is his very first attempt and it has taken 3 years to complete. Laurent is hopeful that there may be a market for what started as a hobby.

Every piece of this vehicle was manufactured by Laurent from scratch and is a faithful replica of the original. It has been assembled exactly the way it would have been back in the early sixties—the only difference being the size. This vehicle is 21 inches long, which makes it a 1/8th scale model.

In order to produce the scale model, Laurent needed the real thing. And what could be better than his own Series II, which is actually a 1964 body on upgraded mechanics with a 1976 engine. He also needed good reference material and for this he turned to Rovers North. Laurent tells me that the RN site is one of the best resources on the web for parts information, drawings and exploded views of a Series Land Rover. As a customer and great fan of the Rovers North team who support my Defender 110 project, this comes as no great surprise.





Functional front and rear suspension - very detailed brake assembly including wheel brake cylinder, brake shoes and springs. Wheels are fitted with real roller bearings.

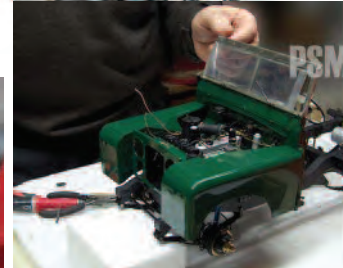

To say the end result is spectacular would be an understatement. Laurent took the finished model to Modelexpo 2010, a modeling competition held near Poitiers and now in its 25th year. Very few competitors build cars because of the complexity. The event is therefore dominated by the more traditional model choices such as boats and planes, all looking to achieve incredible quality and accuracy in a model. It therefore speaks volumes that Laurent's very first model prototype, and his very first competition entry, took overall first prize at the event!

Photographs will never do this model justice. You really need to see the model and witness the detail, the working parts and the quality of workmanship to fully appreciate the excellence. From the pictures, however, anyone familiar with the construction of a Series Land Rover will immediately appreciate that Laurent has gone way beyond

simply creating a copy of the vehicle. The construction of the vehicle and the components used in the real thing have been faithfully reproduced in amazing detail. Even the door skins with a thickness of just 0.2 mm have been reproduced and folded onto the door frame! Since I have spent two years on a Defender restoration, I was able to see just how close to the real thing this is—the Defender of course having evolved from the Series range.

The model is made mainly of brass since at this small scale aluminum is hard to work with. The chassis was mapped to a single sheet of brass scored to create crease lines which, when folded and 'welded,' form the entire box chassis. Every cross member, support bracket and body mount is recreated to create a perfect 1/8th scale replica of the original. The importance of the accuracy becomes all too apparent when you consider that every other part of this model will be created just as the full size original and attached to the chassis in exactly the same way.

1/8 Scale Land Rover Series II



The engine, gearbox, transfer case, axles and differentials were all created using resin and 3-dimensional printing to form resin molds. Tin was then poured into the mold to create the finished article. Serious thought was given to creating moving parts in the engine, however the concept was abandoned since they would never be seen. In future models the tin will be replaced by brass, which is cheaper, better for machining and more importantly, lighter. As with the real thing, weight distribution is important to ensure that the model sits correctly. Having an engine block which is too heavy for the vehicle is a bit like adding a winch to the real thing without first upgrading the springs! It sits nose down. Therefore, not only do the dimensions have to be precise, so does the weight.

Talking to Laurent about the construction process revealed a few surprises. Minute door latches that are functional took just two weeks to produce whereas tires took a staggering three months. Off the shelf tires were never an option and no tire manufacturer was willing to help so they had to be developed from scratch. Molds had to be created first and then tires created from silicone and then painted. They were a little rough at first; however, they have now improved and will continue to improve for future models. Visitors and competitors are still amazed at the quality of them as they are currently.

One of the most interesting aspects of this model is the steering. The steering box on a Series vehicle is always a little sloppy. It is therefore remarkable that a 1/8th scale version of the steering box assembled exactly as the original produces the same play.

Unbelievably, the model, in spite of its size, has a wealth of parts, totalling 3,850. Many of them move, just as they do on the original. Ventilation flaps, door handles and latches, door hinges, the hood release, wipers, sliding windows, support bracket for hood, suspension, steering and lights are just a few. Wherever nuts and bolts or screws are used on the real thing they are found on the model. The wheels nuts are just 2.5 mm and the smallest screws used on the windshield are only 0.4 mm! Every screw is functional so, if necessary, the glass in the windshield can be removed.

So what happens to this model—is it for sale? These were questions I put to Laurent during my visit. This vehicle is not for sale since it is the prototype and will be retained for further development. If, however, someone was prepared to place an order for a model then delivery would be approximately 10 months and it would be built to



Talented modeler Laurent Pierson and his 1/8 scale Land Rover Series II.

customer specifications. Obvious options would be left or right hand drive, colour, mat or gloss finish, hard or soft top and after market accessories. And what about the cost I hear you say? The approximate cost for the model if ordered today is around US \$19,000, plus shipping, although there would likely be a price reduction if multiple orders were received. More than five vehicles of the same type produce significant cost savings thus making the models much more viable to produce. One-off models will always be more expensive.

In my discussions with Laurent about other possibilities in the Land Rover range it became apparent that anything is possible. The obvious choices, based on experience with the Series II, mean that all Series models and Defenders are feasible. It would appear, though, that the Range Rover and Discovery, while being possible to reproduce, would be prohibitively expensive. Laurent estimates that tools alone for these more advanced and curved vehicles would be in the range of \$20,000. Still, if someone is prepared to pay the price of what is undoubtedly a work of art, any one of these models would be the centerpiece of a Land Rover collection—regardless of size.

Is there a market for such a high-end model? Without doubt the US market and the corporate world of Land Rover have to be favourites. In the US many owners of late model Range Rovers have been introduced to the world of Land Rover and have invested in high-end restorations of early Series vehicles. These owners would be prime candidates for a custom model of their pride and joy Series restoration.

Land Rover could surely use a few to grace the entrances to their corporate regional headquarters around the world where the size and availability of full size models depicting the Land Rover heritage might not work—but a PSM model would! //

Behind the steering wheel

By Jeffrey Aronson

A According to tourism bureaus everywhere Memorial Day weekend harkens the beginning of summer. Non-sense! Summer begins when I swap out the safari top for the canvas top.

This absurd ritual has been underway for about 15 years when I first succumbed to lure of a “Land Rover Convertible,” to quote the blandishments of Series III era advertisements. I found a used Land Rover canvas top at a Land Rover rally, a used tailgate from a VA enthusiast, and purchased the hoop set and related parts from Rovers North. It took a day to drill and pop rivet door seals, U-clips for tie downs and tailgate latches. After that one-time challenge, the ritual can now be accomplished in a couple of hours.

Conning three people into helping lift off the safari top in situ makes the job a lot easier, but two can undertake it. Step one involves a lot of unbolting around the windshield header, behind the front seats, between the two jump seats and around the rear door. Step two is to remove the rear door and hinges carefully, particularly if you purchased your new door from Rovers North last year, had it painted professionally and have become anal about how good it looks to you.

Step three is for one person—me—to assume the “Hunchback of Notre Dame” position, one foot on the center seat box cover, the other just over the seat back bulkhead. Person #2—preferably a young, hefty, strong member of the town road crew—stands at the rear opening, hands above his head, lifting the top in the air. Person #1 lifts the front of the top on his shoulders, nimbly steps over the seat back bulkhead and walks the top sternward on his now-aching shoulders until it can be lifted over the rear and carried to its summer storage location.

Step four is to moan loudly and wonder why you go through this misery every year.

Step five involves lifting the hoop set into its factory-installed

“Listening in on cabin conversations is out of the question – you can't even hear the person sitting next to you. Stick with your pre-telecommunicating Land Rovers and you're safe.”

holes and bolting everything back up together. You also get to spend time rummaging through a parts bag wondering why you ever kept all these rusty pieces but have managed to lose the bolts, nuts, washers and cotter pins you really need right now to properly install the tailgate.

Step six requires that you clamber up on the car's side rails to throw the 800-lb Exmoor canvas top over the hoops, tie everything down, and sigh with relief when you discover that it did not shrink



Newlyweds Dan Chapman and Tami Sutherland. Photograph: Lightly Photography by Sarah Rizy, Fort Worth, TX, lightlyphoto.com

after your careless inattentiveness of last summer.

Now I can admire my transformed “Land Rover Convertible.” Of course it rained immediately after I installed the top and will continue to do so for the next three days. At least the Rover becomes easier to use towing a trailer for caretaking and landscaping jobs this summer.

The UK, or at least, England, gave the world a royal wedding in April. Prince William and Kate Middleton provided the kind of ceremony the Brits do so well, enticing millions of viewers on television, reams of print publications and terabytes of digital imagery.

Land Rovers transported toffs, aristocrats, diplomats and posh celebrities to and from the event. The newly-married royal couple even returned to William's work place, the Isle of Anglesey, which has a storied place in Land Rover history.

It's only 130 miles from Solihull to Anglesey, the large island extension of north Wales, but an old farm there offered a respite for Maurice Wilks, who with his brother Spencer, led the management of the Rover Car Company during World War II. The legend goes that in 1947, as their war surplus Jeep began to fail on their rural retreat, Spencer asked Maurice what vehicle would replace the Jeep when it wore out. The answer became the Land Rover.

The US had its own Land Rover-themed royal wedding this past spring, appropriately in the former Republic of Texas. Tami Sutherland, an occasional correspondent for Rovers Magazine, and Dan Chapman drove from their Virginia home to Marble Falls, TX, so they could be wed at this year's SCARR [see Jim Edson's coverage in this issue -ed.] A few years ago, Tami had driven from her home in Florida to attend SCARR; Dan had done the same from Virginia. Romance ensued and the rest is history.

Whereas the UK's royal wedding focused on the theme of a prince marrying a commoner, this Texas-sized ceremony featured Tami, with her regal LR3, marrying Dan, with his more common Discovery II. Two years ago I had the pleasure of hosting a royal visit from them during their vacation trip through New England. While Dan went scuba diving with my former skipper, Tami accompanied me in the QE I for a tootle around the island. In that private moment Tami confessed that the long drive in Dan's kitted out Discovery II made her long for the advanced engineering of her LR3. Fairy tales can come true, and yes, an LR can marry a Land Rover and be very, very happy.

Way back in the early days of personal computers IT types warned that viruses could only infect a computer if you inserted a diskette from an unknown source in your floppy drive. Then came the internet and millions of opportunities for hackers to infect your hard drive with viruses, worms and trojans, or just steal vast amounts of personal data.

We're reliving this possibility as automobiles become connected to cyberspace. If your GM Onstar or Ford Sync system can detect an airbag alert and report an accident automatically, then maybe a hacker could find out the code for your car's keyless entry, manipulate your automated braking/suspension operations, or listen in on interior cabin conversations?

Computer scientists from the University of California, San Diego, and the University of Washington purchased a new car for the sole purpose of demonstrating whether they could hack into its computer systems through the Bluetooth connections in the car. Their report revealed that they could and that automotive manufacturers were already taking this potential threat seriously.

The chances of hackers doing something similar with my Series II-A are more remote. As an EMT, I carry around a portable radio; whenever I've tried to respond to a call while the engine is running, static from the ignition system drowns out all radio communications. The only computer in the car is the laptop in my computer bag. Listening in on cabin conversations is out of the question—you can't even hear the person sitting next to you. Stick with your pre-telecommunicating Land Rovers and you're safe.

Saturday morning in Maine often includes listening to "Car Talk" on Maine Public Radio. Who else would tackle the question as to whether soaking gummed up spark plugs in vodka would render them

useful again ["yes, vodka is a good solvent"]?

Today's episode featured a call from a wife frustrated by her husband's insistence that she share his enthusiasm for car club events they attend in their Mazda Miata. As she said during the broadcast, "We drive a few hours in one direction, have a dinner with other sports car geeks, and then drive home." Instead of focusing on the obvious problem—a boring faux sports car—the Magliozzi brothers suggested she could by now, after two years of marriage, forgo attendance at future events.

Whether married or otherwise this issue raises its head in Land Rover circles, too. Vermont's British Invasion, Connecticut's British By The Sea, and Oregon's British Car Day are static, show-your-shiny-car-to-the-adoring-public events. The challenge is, of course, to make your car mean something to the significant other in your life. After putting a great deal of sweat equity and/or cash into your Land Rover you might become quite paranoid about sharing the driving of your beauty with another person—despite that fact that he/she might legally share ownership in your joint property or have supported your enthusiasm in some significant manner.

At least in Land Rover circles this dynamic is shifting as more couples attend and participate in Land Rover events together. Once the first Range Rover Classic demonstrated that you did not need to possess the strength of Thor or Xena Warrior Princess to operate the steering wheel, there's no reason why your wife or girlfriend cannot take a long turn at the wheel. Indeed, if you're lucky, she'll let you drive her Land Rover, too. ■■

“Once the first Range Rover Classic demonstrated that you did not need to possess the strength of Thor or Xena Warrior Princess to operate the steering wheel, there's no reason why your wife or girlfriend cannot take a long turn at the wheel.”



NPR's Car Talk Tom and Ray Magliozzi in the studio. ©2011 Dewey, Cheetham & Howe. Photo credit: Richard Howard.

Protect your Land Rover



To learn about Waxoyl's superior corrosion protection and to watch our application videos visit www.waxoyl-usa.com

Waxoyl U.P.T. Fabric & Leather Protection

RNW5007 \$18.50



Waxoyl I20-4 Rust Inhibitor

A clear wax that comes in a large 500ml aerosol. RNW5004 \$15.99



Waxoyl Hardwax Underbody

Large 500ml aerosol can perfect for protecting your underbody. RNW5006 \$15.99



Pre-assembled Tailgate Lid Kit with Glass Installed

Corrosion proof, all aluminum tailgate lid for the Range Rover Classic. Comes assembled with Genuine glass and hardware. Does not include exterior handle, latches, hinges, central locking mechanism or brake light. PLB171A \$ 699.00



Aluminum Tailgate Lid Kit

This do-it-yourself kit is a permanent and economical fix for your rusty Range Rover Classic tailgate lid. Kit includes corrosion-proof aluminum frame pieces finished in matte black. Hardware and instructions included. PLH514 \$ 489.00



KBX4121R

Also available with frame in Satin Black and mesh in Brunel Silver.

Defender Sport Side Air Intakes

- Sports styling, strength, & improved air flow
 - Quality injection moulded ABS products designed with attention to detail.
 - Integral ribbed ABS mesh
 - Easy to fit using stainless steel Torx head screws for added security and finish - Torx screws & Driver Bit are included
- Suitable for:** (L) TD, 200 TDi, (R) 300 TDi, TD5 and TDci/Puma Defenders.

Defender Sport Side Air Intakes

Defender Standard, Satin Black, LH	KBX4111L	\$ 109.95
Defender Standard, Satin Black, RH	KBX4111R	\$ 109.95
Defender Premium, Brunel Silver/Java Black	KBX4431L	\$ 139.00
Defender Premium, Brunel Silver/Java Black	KBX4431R	\$ 139.00
Defender Premium, Satin Black/Brunel Silver	KBX4121L	\$ 119.95
Defender Premium, Satin Black/Brunel Silver	KBX4121R	\$ 119.95



NEW GEAR!



KBX4111R



KBX5101

Defender Hi-Force Top Air Intake Set

- Sports styling, strength, & improved air flow
- Includes stainless steel woven wire filter mesh
- Unique multi step louver design provides improved airflow for greater heater efficiency and improved engine bay cooling
- Quality injection moulded ABS products designed with attention to detail
- Easy to fit using stainless steel Torx head screws for added security and finish - Torx screws & Driver Bit are included
- Sold as a pair

Suitable for: all Defenders

Hi-Force Wing Top Set, Defender, Satin Black	KBX5101	\$ 119.95
Hi-Force Wing Top Set, Defender, Brunel Silver	KBX5401	\$ 139.90

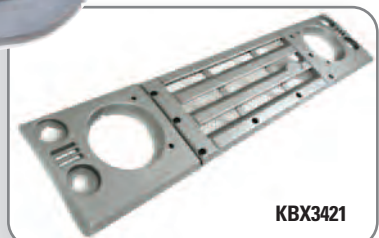

KBX3421

Defender Grille & Lamp Surround Kit



Stainless Steel diamond pattern woven wire backing premium mesh for the grille panel.

Grille Facia Kit Defender, Satin Black Premium	KBX3121	\$ 399.00
Grille Facia Kit Defender, Brunel Silver Premium	KBX3421	\$ 519.00

Land Rover Mud Flaps

Range Rover Classic

Front or Rear (each) flap onlyRNA652 \$ 24.50

Discovery I

Front pair, molded style w/hardwareRNB312 \$ 109.00

Front pair with hardware styled w/logo, flexible, GenuineRNA648 \$ 62.95

Front pair with hardware, plain, flexible, ProLinePLA648 \$ 29.99

RH, Front flap only, flexibleRNH931 \$ 22.90

LH, Front flap only, flexibleRNH930 \$ 22.90

Rear pair, w/hardware, flexible, GenuineRNA649 \$ 59.95

Rear pair, w/hardware, flexible, ProLinePLA649 \$ 29.99

Range Rover P38A

4.0 / 4.6, Front pair, moldedRNB301 \$ 149.00

4.0 / 4.6, '95-96, Rear pair, moldedRNB308 \$ 138.00

4.0 / 4.6, '99-on, Rear pair, moldedRNB317 \$ 139.00

Discovery II

RH, flap only (each) Front or Rear, moldedRND231 \$ 32.50

LH, flap only (each) Front or Rear, moldedRND232 \$ 32.50

Series 88, 109 Regular

Rear pair, styled w/logo, flexibleRNB704 \$ 69.00

Front, without logo, flexible, ProLinePLI557 \$ 39.95

LR2

Front pair with hardware, moldedRNI687 \$ 99.95

Rear pair with hardware, moldedRNI688 \$ 96.95

LR3 up to '09

Front pair with hardware, moldedRNI691 \$ 94.50

Rear pair with hardware, moldedRNI692 \$ 99.50



Discovery II LH Front Window Regulator RNH541

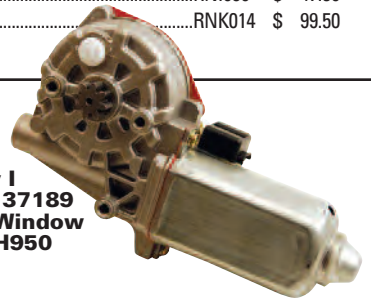

Discovery I up to SA137189 LH Front Window Motor PLH950

Window Regulators & Window Motors

Range Rover

Classic 1995 from SA658967

	Regulator	Motor
RH Front, Genuine	RNH542 \$ 169.95	RNH949 \$ 185.93
RH Front, ProLine	PLH542 \$ 69.00	PLH949 \$ 78.50
LH Front, Genuine	RNH541 \$ 169.95	RNH951 \$ 198.91
LH Front, ProLine	PLH541 \$ 69.00	PLH951 \$ 98.50
RH Rear, Genuine	RNH945 \$ 129.72	RNH951 \$ 198.91
RH Rear, ProLine	PLH945 \$ 69.80	PLH951 \$ 98.50
LH Rear, Genuine	RNH947 \$ 136.21	RNH949 \$ 185.93
LH Rear, ProLine	PLH947 \$ 69.80	PLH949 \$ 78.50

Range Rover

Classic SWB up to SA658966

	Regulator	Motor
RH Front, Genuine	RNH539 \$ 109.50	RNI317 \$ 395.40
RH Front, ProLine	PLH539 \$ 89.50	PLI317 \$ 129.00
LH Front, Genuine	RNH540 \$ 109.50	RNI318 \$ 395.40
LH Front, ProLine	PLH540 \$ 89.50	
RH Rear, Genuine	RNH944 \$ 75.62	RNI323 \$ 202.96
LH Rear, Genuine	RNH946 \$ 79.54	RNI322 \$ 118.22

Discovery I up to SA137189

	Regulator	Motor
RH Front, Genuine	RNH539 \$ 109.50	RNH948 \$ 99.50
RH Front, ProLine	PLH539 \$ 89.50	PLH948 \$ 199.95
LH Front, Genuine	RNH540 \$ 109.50	RNH950 \$ 199.00
LH Front, ProLine	PLH540 \$ 89.50	PLH950 \$ 199.95
RH Rear, Genuine	RNH944 \$ 75.62	RNH952 \$ 319.00
LH Rear, Genuine	RNH946 \$ 79.54	RNH953 \$ 399.85

Defender 90

LH Rear with hardware, flexible (fits RoW Defender 90 only)RNI682 \$ 47.50

RH Rear with hardware, flexible (fits RoW Defender 90 only)RNI683 \$ 57.23

Defender 90, 110

Front pair, with hardware, without logo, flexibleRNF252 \$ 119.50

LH front with hardware, flexibleRNI426 \$ 54.89

RH front with hardware, flexibleRNI684 \$ 57.23

Defender 110

LH Rear with hardware, flexibleRNI685 \$ 47.50

RH Rear with hardware, flexibleRNI686 \$ 47.50

All, Rear pair, styled w/logo, flexibleRNK014 \$ 99.50

Discovery I from SA137190

	Regulator	Motor
RH Front, Genuine	RNH542 \$ 169.95	RNH949 \$ 185.93
RH Front, ProLine	PLH542 \$ 69.00	PLH949 \$ 78.50
LH Front, Genuine	RNH541 \$ 169.95	RNH951 \$ 198.91
LH Front, ProLine	PLH541 \$ 69.00	PLH951 \$ 98.50
RH Rear, Genuine	RNH945 \$ 129.72	RNH949 \$ 185.93
RH Rear, ProLine	PLH945 \$ 69.80	PLH949 \$ 78.50
LH Rear, Genuine	RNH947 \$ 136.21	RNH951 \$ 198.91
LH Rear, ProLine	PLH947 \$ 69.80	PLH951 \$ 98.50

Discovery II

	Regulator	Motor
RH Front, Genuine	RNH542 \$ 169.95	RNH949 \$ 185.93
RH Front, ProLine	PLH542 \$ 69.00	PLH949 \$ 78.50
LH Front, Genuine	RNH541 \$ 169.95	RNH951 \$ 198.91
LH Front, ProLine	PLH541 \$ 69.00	PLH951 \$ 98.50

Discovery II up to 1A719661

	Regulator	Motor
RH Rear, Genuine	RNI315 \$ 229.60	RNH949 \$ 185.93
RH Rear, ProLine	PLI315 \$ 69.50	PLH949 \$ 78.50
LH Rear, Genuine	RNI316 \$ 229.60	RNH951 \$ 198.91
LH Rear, ProLine	PLI316 \$ 69.50	PLH951 \$ 98.50

Discovery II from 1A719662

	Regulator	Motor
RH Rear, Genuine	RNI315 \$ 229.60	RNI319 \$ 189.00
RH Rear, ProLine	PLI315 \$ 69.50	
LH Rear, Genuine	RNI316 \$ 229.60	RNI320 \$ 189.00
LH Rear, ProLine	PLI316 \$ 69.50	



Static Shoulder Harness

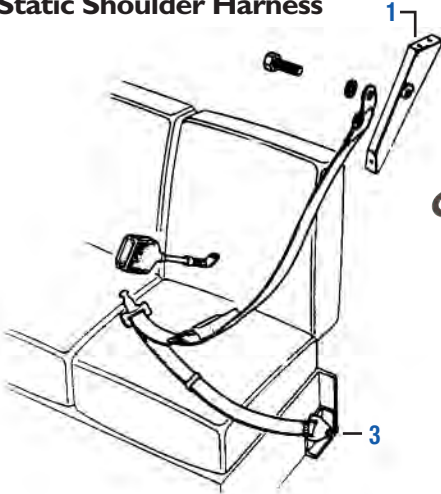

Static Shoulder Harness Kit

3 Point Series IIA & IIIPLF353 \$ 61.95



Upper Defender Seat belt Bracket for Hard Tops

Upper RHRNC112 \$ 8.41
Upper LH (Driver).....RNC113 \$ 8.54

Inertia Shoulder Harness

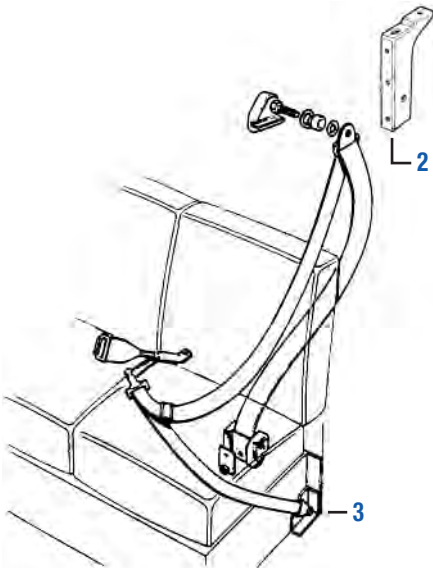

Genuine Inertia Shoulder Harness Kit

Includes bottom mounting bracket.

RH front, Defender 90
RN1873 \$ 200.16

LH front, Defender 90
RN1874 \$ 200.16

Inertia Shoulder Harness Kit

Series & Defender
LH or RH reel,
buckle & hardware.
PLF370 \$ 79.95



Upper Series Seatbelt Bracket for Hard Tops

Upper RH
RNB963 \$ 48.95

Upper LH (Driver)
RNB964 \$ 48.95



Bottom Series & Defender Seat Belt Bracket

Bottom RH
RNB898 \$ 28.50

Bottom LH (Driver)
RNB899 \$ 28.50



Static & Inertia Lap Belts

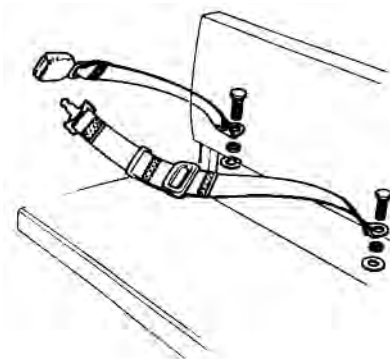

Static Lap Belt

Series & DefenderPLF234 \$ 44.39
Genuine (not shown).....RNF234 \$ 103.89



Inertia Retractable Lap Belt

Series & DefenderPLF234R \$ 52.45



High quality 3 mm 5 bar protection plate, anodized Silver or Powder Coated Black fits all Defenders up to 2007.



1 Mammouth Wing Top Protector

Includes stainless steel hardware - Sold in Pairs

Defender Anodized Silver.....	RNA6510	\$ 169.00
Defender Powder Coated Black.....	RNA6510B	\$ 139.00
Series II-III Anodized Silver.....	RNA1116	\$ 149.00
Gasket Wing Top Protector, pair...	RNA6510G	\$ 29.95

2 Mammouth Bonnet Protection Plate

Includes stainless hardware.

Defender 90, 110, Black.....	RNA6520B	\$ 179.00
Defender 90, 110, Silver.....	RNA6520	\$ 198.00

Mammouth Rear Corner Protectors

Includes stainless steel hardware - Sold in pairs

Defender 90, Black.....	RNA6550B	\$ 69.50
Defender 90, Silver.....	RNA6550	\$ 74.50
Defender 110, Black.....	RNA6551B	\$ 79.50
Defender 110, Silver.....	RNA6551	\$ 89.50



Mammouth Sill Protectors

Includes stainless steel hardware - Sold in Pairs.

Defender 90, Black,	RNA6530B	\$ 119.00
Defender 90, Silver,	RNA6530	\$ 129.80
Defender 110 SW, Black,	RNA6531B	\$ 120.75
Defender 110 SW, Silver,	RNA6531	\$ 135.45



Defender Rear Corner Protection

TerraFirma
Serious 4x4 Accessories

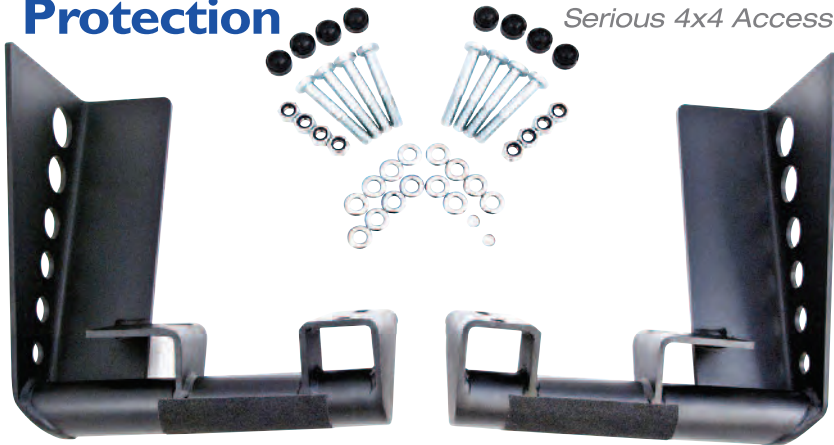

Defender 90/110 Rear Corner Protection Bumperettes

Protects the vulnerable rear lower exposed body corner panels on Defender 90/110. Bolts to the rear chassis cross-member. Includes hardware as shown, black.

Defender 90.....	TF570	\$ 298.00
Defender 110.....	TF571	\$ 298.00

TerraFirma Wheel

7"x16", bead lock ready, shown painted white, RNA100A \$289.00



Rock Sliders

Sold in Pairs

MANTEC

Mantec Defender 90
with jack points.
Black powder coated
RNA1001 \$ 399.00

Mantec Defender 110
with jack points.
Black powder coated
RNA1005A \$ 422.00

ProLine

Series II-III 88"
Proline galvanized
RNA1011 \$ 395.00

Series III 109"
Proline galvanized (special order)
RNA1109S3 \$ 459.64

Discovery I and RRC SWB
Proline with jack points.
Black powder coated
RNA2014 \$ 589.00



RNA2014

Terrafirma

Serious 4x4 Accessories

Terrafirma Rock Sliders with Tree Bars

Sold in Pairs

Defender 90
With Tree Bars
TF801 \$ 399.00

Defender 90 Galvanized
with Tree Bars
TF801GAL \$ 429.00

Defender 110
Black with Tree Bars
TF810 \$ 499.90

Discovery I
Black with Tree Bars
TF807 \$ 699.00

Discovery II
Black with Tree Bars
TF809 \$ 699.00



TF801

Rovers North Front Alloy Skid Plates

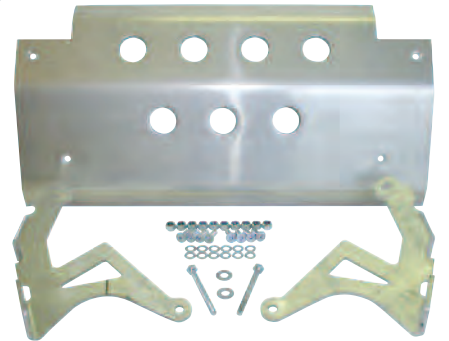

Range Rover Classic & Discovery I
Front Alloy Skid Plate.....RNA4111 \$ 469.00

Discovery II
Front Alloy Skid Plate.....RNA4117AA \$ 459.00

Defender
Front Alloy Skid Plate.....RNA4113 \$ 439.00

Differential Guards

Range Rover P38A
Discovery II 2003-'04 Front
DIFF03 \$ 179.00

DIFF03



Range Rover Classic, Discovery I & Defender
Front or Rear - Galvanized
DIFF01AA \$ 79.95 ea

Discovery II (non-ACE only)
Front DIFF02AA \$ 79.00

DIFF01AA



Receiver Hitch Adapter for Tow Jaw

For 2" receivers
RNA082 \$ 59.00

Tow Jaw Assembly

7,700 lb Camel
Trophy Style
By Dixon Bates
RNF408 \$ 89.90



Shackle Mount

For 2" Receiver w/Hitch Pin
RNA1022 \$ 49.98



Featured in July 2011 Issue



Aluminum Traction Sand Mat

60" x 17" - Sold in pairs.....RNP1004 \$ 389.00

Sand Track Mount Bracket

Sold in pairs.....RNP1004MB \$ 99.90

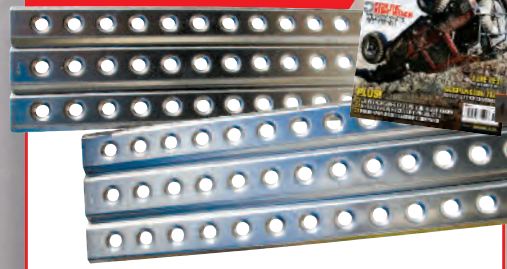

Terrafirma Wheel

7"x16", bead lock ready,
shown painted white.

RNA100A \$ 289.00

Win

“When we get the feeling of becoming bogged down or losing progress we generally over throttle.”

W

While running trails—even with experienced wheelers—I am

often amazed at how fast folks forget basic recovery safety rules and rigging protocols. Let's review some so we can keep our off-roading safe and our vehicles secure.

Many of you can relate to this scenario: “Oh no, we're stuck! Let's just pull out 10 or 20 feet of line, hook it to Fred's rig right there and winch ourselves out.” So a helpful soul grabs the winch cable or rope with his bare hands, pulling slack to the rig in front, attaching it to the first point he finds, and then winching as fast as possible.

First off, most of us hate to get stuck. We install air lockers, flexible suspensions and big tires so we won't have to winch. We would like to be able to just drive, not winch ourselves, out or over obstacles. Winching feels inconvenient, so we try to get it over with as quickly as possible. How many people have you seen that won't use the winch just to keep from “messing” the cable or rope? Since we're likely to get stuck at some point on a trail run, let's deal with it calmly and thoughtfully.

As I've recommended in earlier columns, do a proper “stuck assessment.” You should be doing stuck assessments before getting stuck! As I'm driving up a muddy slope I'm already looking at the recovery point options for the “what-if” of getting stuck. I'll drive as best I can by sawing the wheel back and forth to gain traction, trying to keep good contact patches on the tires and keeping momentum going. When we get the feeling of becoming bogged down or losing progress we generally give our Rover too much throttle. Resist that temptation as it can cause digging in, making the situation worse. Some of us “catch” reverse to back out of a situation before becoming mired, but backing up too quickly may cause problems we didn't anticipate, so I typically stay with the forward progress and a preemp-

Winning Out

BURKE'S CORNER

JUNE 2011

[Bill Burke, Fruita, CO, is one of America's foremost off-road instructors through his Four-Wheel America program. Here's his winning advice -ed.]



tive stuck assessment just in case. When the going gets tough, look ahead with a critical eye for good winch anchor points.

The second area for improvement in the above scenario is choosing the right distance between the anchor point and the recovery vehicle. Manufacturers rate and test their winches at the first layer from the bare drum. They have the most





1986 - 2011

BB4WA

25 YEARS!

Bill Burke's 4-Wheeling America LLC
 Premier Training - Guided Back Country Trips & Expeditions
 970-858-3468 www.bb4wa.com

P.O. Box 430, Fruita, CO 81521 USA
 970-858-3468
 bb4wa@bb4wa.com



power there so it is important to rig with the correct line length. *[It's simple physics; the larger the diameter of the spool, the more line the winch pulls in per degree of rotation, thus the winch works harder with a bigger spool of line.]*

The red Jeep in the photo provides a real life example of this scenario. There was a 5,500-pound vehicle with its belly pan on a ledge and the front tires in the air with no traction. The vehicle likely has a compounded weight of close to 8500 lbs. During this stuck situation, the owner wanted to pull the vehicle from about 20 feet away. Given the 8,000-pound winch rating and the 125 feet of rope on the drum, the winch would have gone to the stall point before extracting the vehicle.

I suggested that the folks move the anchor vehicle forward and use a snatch block. This increased the pulling power by putting the winch line in the sweet spot, then the pulley doubled up the power, resulting in more than twice the power of the previous rigging plan. The vehicle came off the rocks with some resistance since the belly pan and frame were dragging on the rock, but the winch worked easily. The rope wound on the drum evenly and with good tension. Again, time spent doing proper rigging pays off with a smooth recovery.

The most common excuse for poor rigging is to save time as it is often assumed proper rigging takes longer. Unfortunately quick and dirty rigging is not only more dangerous, it often needs to be redone when it proves insufficient. Clearly doing it right the first time is quicker!

Lastly, please don't handle winch line with your bare hands. Wire cable routinely has burrs that can really slice into your hands; putting on proper gloves takes a lot less time than bandaging up lacerated hands or fingers. You'll be surprised at the burn that plasma rope can cause, too. So regardless of whether you have a metal or synthetic winch line, wear sturdy gloves.

Instead of seeing getting stuck as an inconvenience, try to view it as a fun new challenge and an opportunity to practice vehicle recovery. If you practice winching with a good plan, solid rigging and patience, it will become second nature. Hone your skills so you are ready when the mud really hits the fan!

See you on the trail. //

Bill Burke

Lift-Mate

Lift directly from the wheel
LM100 \$37.95



Jack Adapter

For use with Hi-Lift Jacks only. Fits into receptacles located on Defender chassis, rock sliders & winch bumpers offered by Rovers North.
PLA908HL \$59.00

Hi-Lift Jack Base

Use for soft ground.
ORB \$36.50

Hi-Lift Cast & Steel Jack

60 inch
HL605 \$68.50

Hi-Lift Cast & Steel Jacks

36 inch
HL364 \$55.00
42 inch
HL424 \$56.00

Hi-Lift X-TREME Jacks

48 inch
XT485 \$87.90
60 inch
XT605 \$89.90

Hi-Lift



Marlow Kinetic Rope

Exclusively issued by the British Military for Land Rover use. Far superior to recovery straps. Requires securely fastened recovery hitches for safe use. Kinetic Rope 24mm diameter x 8m, 12,030kg (26,500lb) military rating. KRR001 \$129.00



Plasma Winch Rope

The best plasma ropes available. Safer and stronger than wire.

3/8" Plasma Rope; 100'
RNR2021 \$279.00

5/16" Plasma Rope; 125'
RNR2011 \$259.00



NEW Quick Fist Clamps

1. Mini Quick Fist .62-1.3" dia.

Holds objects from 5/8" to 1 3/8" (16 to 32mm) in diameter. Each clamp supports a safe working load of 25lbs (11 kilos). 2 clamps support 50 lbs (23 kilos). 2 Clamps Per Package. 30050 \$ 6.99

2. Quick Fist 1"-2.5" dia.

Holds objects 1" to 2.25" (25 to 57mm) in diameter. Each clamp supports a safe working load of 25lbs (11 kilos). 2 clamps support 50lbs (23 kilos). 2 Clamps Per Package. 10010 \$ 9.50

3. Super Quick Fist 2.5"-9.5" dia.

Holds objects from 2.5" to 9.5" (64 to 240mm) in diameter. Each clamp supports a safe working load of 50lbs (23 kilos). 2 clamps support 100lbs (45 kilos). 1 Clamp Per Package. 20020 \$ 4.93

4. Quick Fist XL 28"

Two 14" (356mm) separate straps hold round objects up to 15" (381mm) in diameter. Holds equipment measuring up to 28" (711mm) in linear distance. Each clamp supports a safe working load of 150lbs. (68 kilos) with a break-strength of 300lbs. (176 kilos). Two clamps support 300lbs with a break-strength of 600lbs (272 kilos). 2 Clamps Per Package. 60060 \$ 21.99

5. Quick Fist 3", 2.75"-3.25" dia.

Holds objects from 2 3/4" to 3 1/4" (70mm to 83mm) in diameter. Each clamp supports a safe working load of 50lbs (23 Kilos). 1 Clamp Per Package 50050 \$ 9.50

6. Quick Fist Long Arm .5"-4.5" dia.

Holds objects from 1/2" to 4.5" (13mm to 114mm) in diameter. Each clamp supports a safe working load of 50lbs (23k). Break strength is 120lbs (55k). 2 Clamps Per Package. 40010 \$ 8.98



Buy Quick Fist Clamps
www.roversnorth.com/quick-fist



Chassis - Series II, IIA, III, Defender 90, 110

Start your restoration with a new galvanized chassis from Rovers North.

We offer galvanized chassis manufactured from both Marsland or Richards for your Series II, IIA, III, Military or Defender 90 NAS and Defender 110 V8.

Complete Galvanized Chassis Assemblies

88" Series IIA, III, Marsland	RNE416	\$2499.00
88" Series IIA, III, Richards	PLE416	\$1999.00
88" Series II Richards	PLE4162	\$1999.00
109" Regular (pickup) Series IIA, III, 2.25 ltr., Richards	PLE412	\$3195.00
109" Military, Series IIA, III, 2.25 ltr., Richards	PLE414	\$3295.00
109" Station Wagon Series IIA, III, 2.25 ltr., Richards	PLE413	\$3195.00
109" Station Wagon Series IIA, III, 2.6 ltr., Richards	RNH416	\$3395.00
Defender 90 NAS V8, Marsland	RNC878	\$3290.00
Defender 110 V8, Marsland	RNH710	\$3499.00

- 1. Rear Frame Member in Black Finish with 18" Extensions, includes spring shackle**
Mounts for 88.....RNE404 \$ 229.00
Military 88 & 109.....CHAS23 \$ 269.95

Rear Frame Member Mounting Kit For use with RNE403. Includes all pieces necessary to mount rear frame member to existing frame rails (not assembled).

- 2. 88" Rear Frame Member Mounting Kit**.....CHAS01 \$ 139.95
109" Rear Frame Member Mounting Kit.....CHAS02 \$ 119.00
- 3. 88" Rear spring perch, Supplied with spring bushing**.....RNF377 \$ 135.79
109" LH Rear spring perch.....RNF382 \$ 86.92
109" RH Rear spring perch.....RNF383 \$ 86.92

- 4. 109" Front of rear spring outrigger, left**.....RNF381 \$ 153.49
- 5. 88" Body Support Outrigger and Fuel Tank Mount, right**.....RNF380 \$ 68.00
88" Body Support and Fuel Tank Mount, left.....RNF379 \$ 93.95
109" Body Support & fuel tank mount, right.....CHAS20 \$ 81.90
109" Body Support & fuel tank mount, left.....CHAS21 \$ 98.50

- 6. 88" Fuel Tank Front Outrigger RH**.....PLF378 \$ 59.80
109 Fuel Tank Front Outrigger RH.....CHAS19 \$ 69.00
- 7. 88" Bulkhead outrigger**.....CHAS09 \$ 89.95
109" Bulkhead outrigger.....RNF458 \$ 119.95

- 8. 88" Transmission cross member**.....RNA950 \$ POA
109" Transmission cross member.....CHAS22 \$ 93.40

- 9. Front horn assembly, right Fits all civilian 88" & 109"**.....CHAS11 \$ 139.00
Front horn assembly, left Fits all civilian 88" & 109".....CHAS12 \$ 139.00

Repair Kit for Front Horn Contains all the pieces to rebuild one frame horn (not assembled) Series IIA.....CHAS13A \$ 59.95
Series III.....CHAS13B \$ 59.95

- 10. Auxiliary Fuel Tank Outrigger**.....CHAS05 \$ 60.90

Battery Casing and Air Cleaner Support

Series II, IIA, III, 2.25 petrol

- 11. Wing Nut**.....RNB576 \$ 5.55
- 12. Stud for Wing Nut**.....RNA983 \$ 13.36
- 13. Hold Down Bracket for Battery, 2.25 litre**.....RNC506 \$ 18.22
- 14. J-Bolt Late Series IIA, III**.....RNC417 \$ 5.03

Replacement Floor Panels

Defender 90, 110

Reproductions of exact factory units, these hand crafted 18 gauge steel units are galvanized* and ready to fit into your Defender for a proper restoration.



- 15. Floor Panel, LHF Outer, 90/110 NAS, galvanized**.....RNF0012 \$ 69.95
Floor Panel, LHF Inner, 90/110 NAS, galvanized.....RNF0014 \$ 45.95
Floor Panel, LHF Upper 90/110 NAS, galvanized.....RNF0018 \$ 89.95
Floor Panel, RHF Inner 90/110 NAS, galvanized.....RNF0015 \$ 45.95
Floor Panel, RHF Outer 90/110 NAS, galvanized.....RNF0013 \$ 69.95
Floor Panel, RHF Upper 90/110 NAS, galvanized.....RNF0019 \$ 79.95
- 16. Kick Panel, LHF Outer 90/110 NAS, galvanized**.....RNF0016 \$ 49.95
Kick Panel, RHF Outer 90/110 NAS, galvanized.....RNF0017 \$ 49.95
- 17. Kick Panel, LHF Inner 90/110 NAS, painted steel**.....RNF0020 \$ 119.95
Kick Panel, RHF Inner 90/110 NAS, galvanized.....RNF0021 \$ 79.95

*All parts are galvanized except RNF0020 which is painted.



Series 109" Station Wagon Chassis with Auxiliary Fuel Tank Outriggers Illustrated

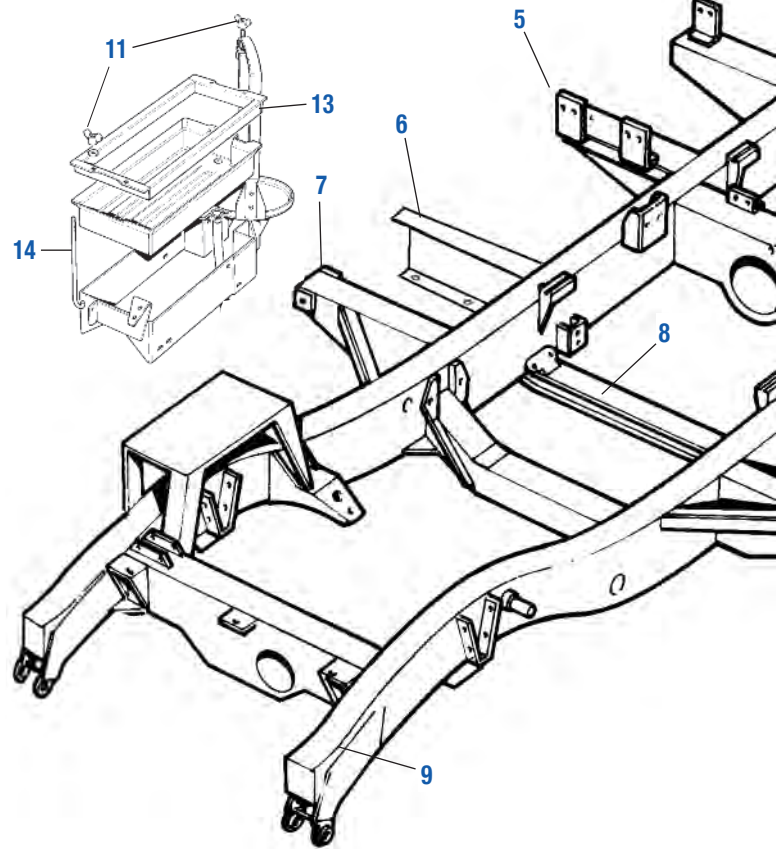

18 ga. Galvanized Replacement Footwell Parts

Series II, IIA, III 2.25 litre Bulkheads

- 18. Toe Board, Replaces front angular floor section, galvanized.**

Right Side as illustrated.....	RNF0003	\$ 59.95
Right Side Simplified quick repair version.....	FLOOR3	\$ 41.58
Left Side as illustrated.....	RNF0002	\$ 59.95
Left Side Simplified quick repair version.....	FLOOR2	\$ 41.58

- 19. Kick Panel** Triangular panel located on the inside of the door post. Has flanged corner to interconnect with replacement toe board to reconstruct a rusted through floor area. Galvanized.

Left Side complete panel.....	RNF0001	\$ 47.95
Left Side Simplified quick repair version.....	FLOOR1	\$ 41.58
Right Side complete panel.....	RNF0004	\$ 47.95
Right Side Simplified quick repair version.....	FLOOR4	\$ 41.58

- 20. Footwell Top, Left Side**.....FLOOR7* \$ 65.80
Footwell Top, Right Side.....FLOOR8 \$ 39.38

- 20a. Footwell Replacement Assembly - Galvanized**

Parts 1, 2 & 3 assembled as a unit. Replaces entire footwell, ribbed		
Driver's Side.....	RNF0005*	\$ 187.90
Passenger's Side.....	RNF0006	\$ 151.73

*The brake pedal cutout is for single system Master Cylinder When installing later dual power Master Cylinder, the cutout will need to be lengthened.

- 21. Door Post Replacement**

Now supplied as 2-piece replacement. Extends further up the bulk head and includes hole for upper hinge, ensuring accurate hinge spacing.

RH Door Post 25" tall.....	CHAS18	\$ 109.00
LH Door Post 25" tall.....	CHAS31	\$ 69.20

Chassis - Series II, IIA, III, Defender

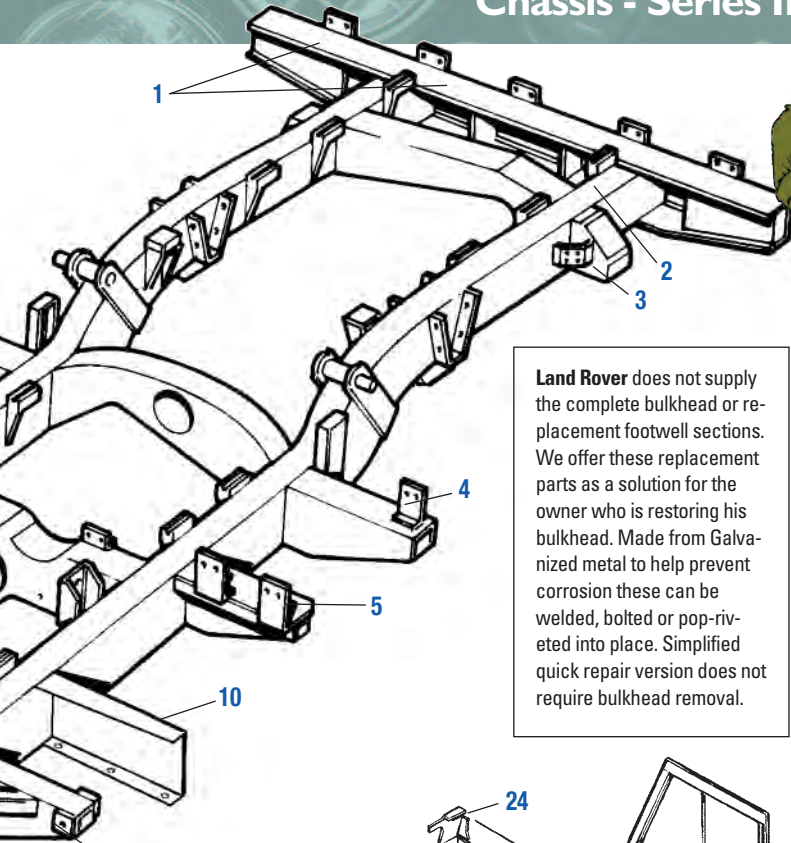

Land Rover does not supply the complete bulkhead or replacement footwell sections. We offer these replacement parts as a solution for the owner who is restoring his bulkhead. Made from Galvanized metal to help prevent corrosion these can be welded, bolted or pop-riveted into place. Simplified quick repair version does not require bulkhead removal.



Replacement chassis parts

Welding is required to install these parts and should be referred to a professional. For the do-it-yourself Land Rover owner the job requires a cut off wheel and/or torch, 4" grinder and a 60 amp welder. Try 3/32" 6011 rods at 60 amps (45 amps DC) for best results.



PLE403
\$299.00

Series II, IIA, III Galvanized Rear Cross Member



PLH619G
\$389.00

Defender 90 NAS Galvanized Rear Cross Member

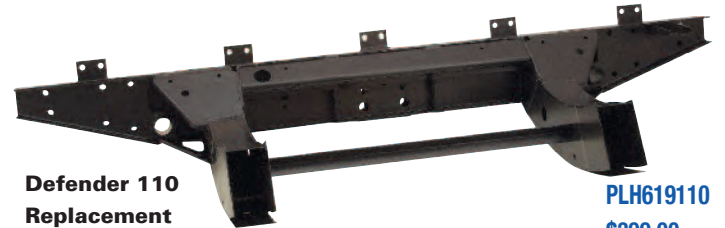

PLH619110
\$399.00

Defender 110 Replacement Cross Member with 18" Extensions



PLH61990
\$398.00

Defender 90 Replacement Cross Member with 18" Extensions

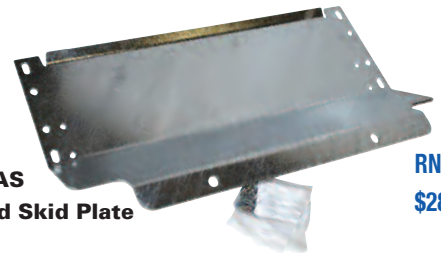

RNAFT01
\$286.00

Defender 90 NAS Fuel Tank Guard Skid Plate

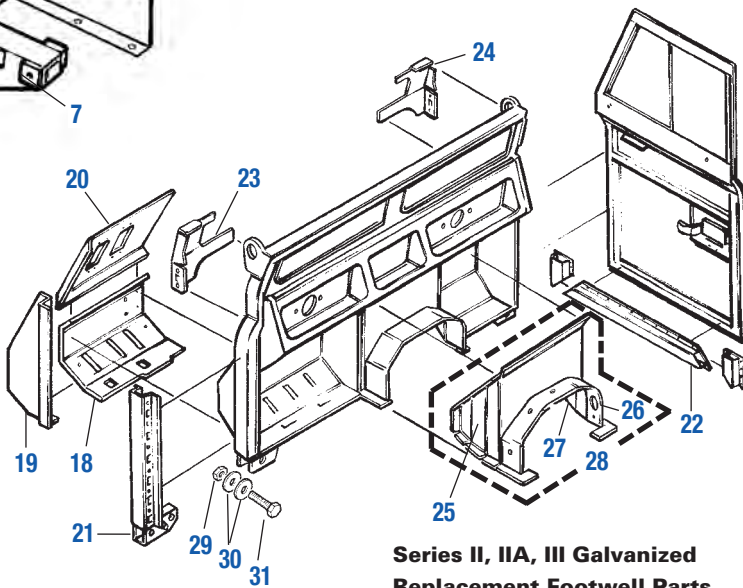

Series II, IIA, III Galvanized Replacement Footwell Parts

21. Door Post Replacement, con't.		
RH Foot.....	CHAS32	\$ 34.95
LH Foot.....	CHAS33	\$ 27.09
One Piece LH as illustrated 183/4" tall.....	CHAS17	\$ 109.00
One Piece RH as illustrated 183/4" tall.....	CHAS18	\$ 109.00
22. Door Rails – Galvanized		
Door Frame Repair Kit (replaces rusted bottom door frame).....	CHAS24	\$ 79.95
23. Bulkhead Corner LH Repair Piece.....	CHAS36	\$ 48.50
24. Bulkhead Corner RH Repair Piece.....	CHAS35	\$ 48.50
25. Center Kick Panel LH.....	RNF0007	\$ 58.90
26. Flange Only, for Gearbox Tunnel.....	RNF0008	\$ 92.30
27. Center Kick Panel RH.....	RNF0009	\$ 58.90
28. Center Bulkhead Assembly.....	RNF0010	\$ 279.00
29. Nut.....	RNF459	\$ 3.46
30. Washer.....	RNF460	\$ 0.47
31. Bolt, Bulkhead to Outrigger.....	RNF461	\$ 6.84

Tool Locker Replacement Assembly For Seat Box – Galvanized

15. Series III (Will also Fit Earlier Models).....	CHAS28	\$ 144.00
16. Series II, IIA With Battery Facility.....	CHAS29	\$ 160.29

Hot Dipped Galvanized Rear Cross Member

Series II, IIA, III.....	PLE403	\$ 299.00
Defender 90 NAS.....	PLH619G	\$ 389.00

Replacement Cross Member with 18 inch Extensions

Defender 110, Black non-galvanized.....	PLH619110	\$ 399.00
Defender 90, Black non-galvanized.....	PLH61990	\$ 398.00

Hot Dipped Galvanized Fuel Tank Guard

Defender 90 NAS, Galvanized skid plate. Replaces original sheet metal cradle. Sold with Hardware.....	RNAFT01	\$ 286.00
---	---------	-----------

Tough & Reliable Suspension Choices for On and Off-Road



25 1/4"

Bilstein



25 1/2"

OME



25 1/2"

TerraFirma Big Bore



28"

TerraFirma Pro Sport



28"

Pro Comp

Displayed to extended length to demonstrate actual size differences.



ES9000 + 2 inch Raised Shock Kits

Nitrogen gas

charged shocks with two inches of extra travel. (Designed for off-road performance for vehicles with raised suspension of two inches or less). Excellent all around ride quality and handling. Shock sets include bushings and optional poly vinyl dust boots in black. Sold as set of four.

Discovery I 1989-1999

Front & Rear Shock Kit.....PCS9030 \$ 199.00
Steering Damper.....PLS122 \$ 44.50

Range Rover Classic 1987-1993 with coil suspension

Front & Rear Shock Kit.....PCS9050 \$ 199.00
Steering Damper.....PLS122 \$ 44.50

Defender 90/I I 10 1983-1998

Front & Rear Shock Kit.....PCS9020 \$ 199.00

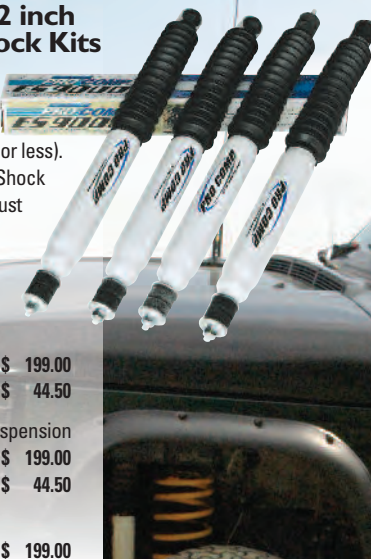

Pro Sport + 2 inch Shocks

Exclusively designed for off-roading Land Rovers.

This is a true +2" longer than standard shock. The advantages when driving off-road are remarkable as these shocks are built with hardcore use in mind. Fitted with velocity sensitive valving means the shock will automatically adjust its internal damping to suit driving conditions, the harder you punish them the better they work. On the drive home you'll really notice the superior ride quality and handling. Kits sold as set of four.

Discovery I 1989-1999

Range Rover Classic 1987-1993 w/coil susp.

Defender 90/I I 10 1983-1998
Front and rear shock kitRNK722 \$ 289.00

Discovery II 1999-2004

Front Pro Sport + 2" Shock, eaRNA127 \$ 69.99
Rear Pro Sport + 2" Shock, ea.....RNA128 \$ 69.99

Steering Damper

Discovery I 1989-1999, Range Rover Classic 1987-1995

Steering Damper.....RNA811 \$ 60.90

Defender 90/I I 10 1983-2010

Steering Damper.....RNA832 \$ 60.90



ES9000 Standard Length Shock Kits

These Pro Comp ES9000 dual action nitrogen gas shocks incor-

porate a twin-tube cellular gas design that prevents foaming and reduces shock fade to improve the ride quality of leaf spring suspension. Shock sets include bushings and optional poly vinyl dust boots in black. Sold as set of four.

Series II, IIA, III

Front & Rear shock kit 109"PCS3109 \$ 189.00
Front & Rear shock kit 88"PCS3088 \$ 189.00

Discovery I, Range Rover Classic, Defender 90/110

Front & Rear Shock Kit.....PCS9000 \$ 199.00

Steering Damper

Series II, IIA, III, 88", 109"

Range Rover Classic

Discovery IPLS122 \$ 44.50



Big Bore Expedition + 2 inch shocks

Developed specifically for fully laden working Land Rovers.

Features include:

- 76mm body, twin tube design • 50mm internal bore and piston
- 20mm double chromed shaft • High temperature oil fluid
- 2.5mm outer shock tube wall thickness
- 14mm mounting pins. Superior all around performance. Sold as set of four.

Discovery I 1989-1999

Range Rover Classic 1987-1993 with coil suspension

Defender 90/I I 10 1983-1998
Front and rear shock kitRNK721 \$ 299.00

Steering Damper

Discovery I 1989-1999

Range Rover Classic 1987-1993

with coil suspensionRNA811 \$ 60.90

Defender 90/I I 10 1983-1998.....RNA832 \$ 60.90



OME Nitro Charger Sport Standard Length Shocks & Steering Dampers

For Land Rover owners who require heavy-duty shocks, off-road performance and maximum load capacity. New dual stack twin disc technology features an interactive, multi-stacked rebound and compression valving system that ensures optimal damping performance in all conditions. For applications where more dampening is needed for use with oversize tires. Sold as set of four.



Series IIA, III

Set of four shocks, 88".....	OMESK88	\$ 359.00
Set of four shocks, 109".....	OMESK109	\$ 359.00

Defender 90/110 1983-2002

Set of four shocks.....	OMESKDEF	\$ 396.00
Steering Damper.....	OMESD32	\$ 84.50

Discovery I 1994-1999

Set of four shocks.....	OMESKDS1	\$ 396.00
Steering Damper.....	OMESD11	\$ 89.00

Discovery II 1999-2004

Set of four shocks.....	OMESKDS2	\$ 396.00
Steering Damper.....	OMESD02	\$ 84.50

Range Rover Classic 1987-1995

Set of four shocks.....	OMESKRR	\$ 379.00
Steering Damper.....	OMESD11	\$ 89.00



Old Man Emu Heavy Duty Springs & Shock Kits

Ideal for owners using oversize tires combined with heavy duty bumper/winch combinations and extra vehicle equipment. Designed for heavy duty off-road use. Will raise vehicle approximately 1inch. Great off-road, fair on-road. Includes 4 OME Nitro Charger Sport Shocks & 4 OME springs. Imported from Australia. Standard Length.



Defender 90 1984-2002

Standard Duty.....	OMED90K1	\$ 759.00
Heavy Duty.....	OMED90K2	\$ 758.00
Steering Damper.....	OMESD32	\$ 84.50

Defender 110 Station Wagon 1983-2002

Standard Duty.....	OMED110K1	\$ 725.00
Heavy Duty.....	OMED110K2	\$ 759.00
Steering Damper.....	OMESD32	\$ 84.50

Defender Pick Up or Hardtop 1983-2002

Standard Duty.....	OMED110RK1	\$ 725.00
Heavy Duty.....	OMED110RK2	\$ 725.00
Steering Damper.....	OMESD32	\$ 84.50

Discovery I 1994 - 1999

Standard.....	OMEDS1K1	\$ 725.00
Heavy Duty.....	OMEDS1K2	\$ 725.00
Steering Damper.....	OMESD11	\$ 89.00

Discovery II 1999-2004

Standard.....	OMEDS2K1	\$ 725.00
Heavy Duty.....	OMEDS2K2	\$ 725.00
Steering Damper.....	OMESD02	\$ 84.50

Range Rover Classic 1987-1993 Coil spring

Standard.....	OMERRK1	\$ 725.00
Heavy Duty.....	OMERRK2	\$ 739.00
Steering Damper.....	OMESD11	\$ 89.00

Bilstein Standard Length Shocks & Steering Dampers

The world leader in gas-pressurized shock absorber technology. Bilstein utilizes a one piece seamless monotube design filled with oil and nitrogen gas in a pressurized, sealed compartment. We recommend for use with Land Rover Genuine Standard or Heavy Duty springs in normally equipped vehicles. Not recommended for heavily laden vehicles with oversize tires. Lifetime warranty. Sold as set of four.



Defender 90/110 1983 - 2002

Set of four shocks.....	RNA243-4	\$ 359.00
Set of four shocks & damper.....	RNA243-5D	\$ 399.00
Steering Damper.....	RNA235	\$ 88.50

Discovery I 1994-1999

Set of four shocks.....	RNA243-6	\$ 358.00
Set of four shocks & damper.....	RNA243-7	\$ 399.00
Steering Damper.....	RNA245	\$ 79.95

Discovery II 1999-2004

Set of four shocks.....	RNA6046-7	\$ 599.00
Steering Damper.....	RNA246	\$ 89.95

Range Rover Classic w/coil springs 1987-1995

Set of four shocks.....	RNA243-4	\$ 359.00
Set of four shocks & damper.....	RNA243-5	\$ 429.00

Range Rover Classic LWB w/ air suspension

Set of four shocks.....	RNA2152-3	\$ 389.00
Steering Damper.....	RNA245	\$ 79.95

Range Rover P38A 1999-2002

Set of four shocks.....	RNA2214-5	\$ 429.00
-------------------------	-----------	-----------



Heavy Duty Springs & Pro Comp +2 inch Shock Kits

Designed for owners who want the most suspension lift possible without modifications. A true 2 inch taller spring and shock kit. Ideal for owners using oversize tires combined with heavy duty bumper/winch combinations and extra vehicle equipment. Designed for all round use. Great off-road, excellent on-road. Includes 4 Pro Comp Nitrogen Charged + 2 inch shocks & ProLine springs. Springs imported from England - shocks made in the USA.



Defender 90 1984-2002

Standard Duty.....	RNK450	\$ 499.00
Heavy Duty.....	RNK451	\$ 499.00

Defender 110 1983-2002

Heavy Duty.....	RNK452	\$ 499.00
-----------------	--------	-----------

Discovery I 1994-1999

Standard.....	RNK453	\$ 499.00
Heavy Duty.....	RNK454	\$ 499.00

Range Rover Classic 1987-1993

Coil spring Standard.....	RNK455	\$ 499.00
Heavy Duty.....	RNK456	\$ 499.00



Heavy Duty Springs & Shock Kits

Unlike other suspension brands, TerraFirma is exclusively developed for Land Rover vehicles. TerraFirma suspension kits will raise your Land Rover approximately 2 inches above factory ride height, increasing body clearance, wheel travel and approach and departure angles. This will allow your Land Rover to tackle larger obstacles off-road without exceeding factory suspension limits that would compromise its handling on-road. Powder coated silver finish, imported from England.

Discovery II + 2 inch Heavy Duty Suspension Kit

Includes 4 TerraFirma + 2 inch All Terrain shocks and 4 + 2 inch springs. Designed for Discovery II's with extra large tires and extra accessory weight. Very good off-road, very good on-road.

Discovery II 1999-2004		
Heavy Duty.....	..RNK723	\$ 599.00
Steering Damper.....	..RNA802	\$ 60.00



Pro Sport + 2 inch Heavy Duty Suspension Kit

Includes 4 TerraFirma + 2 inch Pro Sport shocks and 4 + 2 inch springs. Great off-road, Excellent on-road.

See More TerraFirma Parts
www.roversnorth.com/terrafirma

Range Rover Classic 1987-1993		
Coil spring Heavy DutyRNK724	\$ 599.00
Defender 90 1984-2002		
Heavy Duty.....	..RNK725	\$ 599.00
Defender 110 1983-2002		
Heavy Duty.....	..RNK727	\$ 629.00
Discovery I 1994-1999		
Heavy Duty.....	..RNK726	\$ 599.00
Discovery I 1989-1999		
Range Rover Classic 1987-1993 with coil suspension		
Steering Damper.....	..RNA811	\$ 60.90
Defender 90/110 1983-1998		
Steering Damper.....	..RNA832	\$ 60.90



Series 88" Spring & Shock Kit

Standard duty Spring set with U-bolts and shocks.

88 Series II, IIA, III.....	..PLK5123	\$ 539.00
-----------------------------	-----------	-----------



Series 88" Spring & Pro Comp Shock Kit

Standard Duty spring set with U-bolts and Nitrogen charged Pro Comp shocks.

88 Series II, IIA, III.....	..PLK5223	\$ 599.95
-----------------------------	-----------	-----------



Balanced Parabolic Spring Kits with Pro Comp Shocks

Improve your ride, comfort and get additional axle articulation out of your Series Land Rover. Includes four springs with U-Bolts and hardware. For best results, we've paired them with a set of our Pro Comp Nitro Gas Shocks or OME Nitrocharger shocks. Kits include 4 springs, 4 shocks & U-Bolts.

88" 2 leaf front & 3 leaf rears,		
4 shocks.....	..RNK112388PC	\$ 849.00
109" 2 leaf front & 3 leaf rears,		
4 shocks.....	..RNK1123109PC	\$ 879.00
109" 2 leaf front & 4 leaf rears,		
4 shocks.....	..RNK1124109PC	\$ 879.00



Balanced Parabolic Spring Kits with OME Shocks

Series II, IIA, III Kits include 4 Old Man Emu Shocks, 4 springs, U-Bolts.

88" 2 leaf front & 3 leaf rears,		
4 shocks.....	..RNK112388	\$ 979.00
109" 2 leaf front & 3 leaf rears,		
4 shocks.....	..RNK1123109	\$ 989.00
109" 2 leaf front & 4 leaf rears,		
4 shocks, Heavy Duty set.....	..RNK1124109	\$ 1120.00





Series II, IIA, III Balanced Parabolic Spring Kits without Shocks

Set of 4. Includes U-bolts with nuts.

88" and 109" 2 leaf front &
3 leaf rears.....RNK1123 \$ 689.00

109" 2 leaf front & 4 leaf rears,
Heavy Duty kit.....RNK1124 \$ 699.00

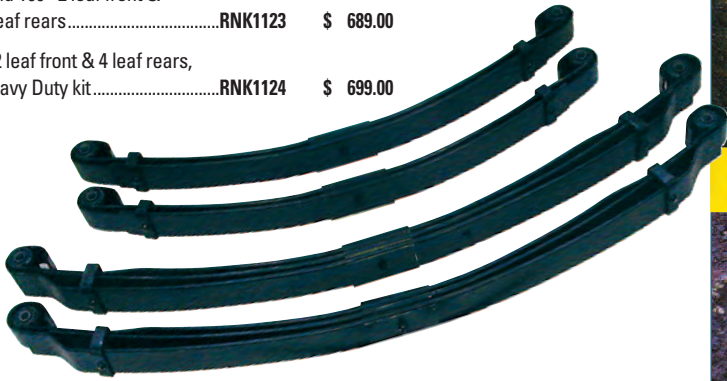

Refresh Your Tired Worn Out Range Rover P38A Air Spring Assemblies with New Units

Range Rover P38A 1995-2002
Front Spring PLD262 \$ 159.00 ea
Rear Spring PLD263 \$ 159.95 ea



Range Rover Classic Coil Spring Conversion Kit

Convert your Range Rover Classic to coil-springs for continued on-road reliability and off-road performance. Our customers have been so satisfied with the improved ride quality and handling after installation of this kit, most claim they prefer the coil conversion suspension to the factory air suspension! This kit contains all Genuine parts, detailed instructions and all necessary hardware.

**Range Rover Classic
Coil Spring Conversion Kit**
RNK5105 \$ 439.00



Range Rover P38A 1995-2002 Coil Spring Conversion Kits

This top quality kit converts your Range Rover P38A air suspension to coil spring suspension, giving you the best handling and the most comfortable coil spring suspension ride on the market today. Our kits include 4 variable rate springs, 2 Genuine rear coil spring isolators, 2 Genuine front coil isolators, 4 coil spring seats, 4 aluminum spring perch adapters, 4 Genuine spring retainers and 1 EAS override pigtail to eliminate fault codes. All hardware and instructions are included. Installation is straight forward, requiring no fabrication or modifications to your vehicle. **Simply the best kit at the best price.**

Range Rover P38A Coil Kit

Genuine Standard Duty.....RNK5106 \$ 879.00*
ProLine Standard Duty.....PLK5106 \$ 659.00**
Genuine Heavy Duty.....RNK5107 \$ 899.00*

Range Rover P38A Coil Kit with Bilstein Shocks

Standard Duty w/ Bilsteins.....RNK5116 \$ 1299.00
Heavy Duty w/ Bilsteins.....RNK5117 \$ 1269.00

* Uses Genuine coil springs
** Uses OEM coil springs



Discovery II Rear Air to Coil Spring Conversion Kit

Kit contains Genuine or ProLine parts, everything for the conversion, instructions and hardware.

Not compatible for vehicles with ACE.

Discovery II, Genuine.....RNK5118 \$ 319.00
Discovery II, ProLine.....PLK5118 \$ 189.95



Text: Anne Stearns
Photos: Maria Carey



[Anne Stearns, Nantucket, MA, is an Emergency Medical Technician at Nantucket Cottage Hospital. A "military brat," she has lived on five islands over the past 25 years. Maria Carey serves as assistant director of the hospital's Emergency Department, operates Charlotte Carey Photography and owns a 2004 Discovery II SE.]





Doctor's *Orders*



The island of Nantucket sits 30 miles off the coast of Cape Cod, MA. Best known for its whaling history and summer colony status, Nantucket also houses an outsized obsession with Land Rovers and four-legged rovers. All year long, Land Rovers cover the paved and dirt roads of Nantucket. Like their automotive counterparts, these pampered pets go everywhere, from work on construction sites to the local shops on Main Street.

One such Rover and rover lover, Dr. Timothy Lepore, has been racing around town in his 1973 Series III 109" SW for decades—usually with all of his dogs right beside him. The son of a physician who served in World War II, Tim Lepore grew up in Marlboro, MA. His fascination with cars started as a teenager, when he would work on his 1955 Chevy, usually with one of the family dogs right beside him. He graduated from Harvard in 1966, and Tufts Medical School in 1970. With his wife, Cathy and children T.J., Meredith and Nicholas in tow, he arrived on Nantucket on New Year's Day of 1983; that night, he performed a cardiac operation at the hospital.

When you're the only surgeon on an island, you're on call 24/7. He travels as the high school sports teams' physician, and given our island's deer population, has become a resource on ticks and Lyme disease. Catching up with him outside the hospital can be a challenge, but once I asked to see his Land Rovers up close, the task became simple.

As Dr. Lepore drove his 109" station wagon to meet me I noticed that he had also crammed three dogs in the front seats. All four occupants wore big grins. Clearly, Lucy and Buddy, his two Nova Scotia duck tolling retrievers, and Millie, the Mississippi mutt, adored riding in the Land Rover.

Dr. Lepore bought his Series III from an island resident in the late 1980's. The odometer reads "about 80,000 miles," but accuracy remains a question; Dr. Lepore feels it gives the car "a little mystery." This Rover still has the original 2.25 cylinder engine, transmission and Fairey overdrive. The Smith's heater doesn't work that well but, "that's

why we wear coats,” he said. Dr. Lepore has added new side mirrors, a new bumper, and installed dog screens, largely ignored by the dogs because they usually demand to sit up front.

“I bought the car because it was easy; as cars became increasingly more complicated throughout the years I wanted a car that I could take care of myself, with a little help from my friendly mechanic. Rovers North has kept me in stock over the years with all the bits and pieces that I need for the car,” he said.

“I love that it takes me wherever I want to go on the island with the dogs. I like that people see the car and know who it belongs to, and I love working on it whenever I can find the time.” Time would be a challenge; Tim was training to run his 43rd Boston Marathon. At least his on-island mechanic loves helping with quick fixes for the 109. “He actually has an old Land Rover in the back of his shop that we will probably use for parts in the future,” Tim said.

Tim also believes that surgery and classic cars share three attributes: “cutting, sewing and tying.” At this moment a bungee cord keeps the back passenger door closed until he can find the time to install a replacement door. While shooting photos for this article, Maria Carey directed Tim to drive up a hill, turn around and come back again.



“Do you have any water,” he asked?

“Sure,” Maria replied, “Is it for your dogs?”

“No,” he said, “It’s for the Land Rover’s radiator.”

His sole-surgeon status does offer some advantages. He notes with a smile that, “I never have a problem getting a tow if I’m stuck on the beach and there is rarely a cross word said to me—at least not until the last stitch is in.” While there are plenty of other classic Land Rovers on the island, only one has the license plate EPON-2. Tim explained that EPON-2 stood for Emergency Physician on Nantucket. “I put the number 2 on because you never want to be the first and now it looks like we have a fleet!”

Well, if two Land Rovers make a “fleet,” then the recent addition of a 1967 Military Lightweight, nicknamed “Chocolate Thunder,” accomplishes the feat. The Lightweight is complete save for a driver’s side door. The 100,000 mile-plus engine needs some fettling, but, “give me time and I’ll have it running smoothly,” Tim assured.

Whether he’s stitching up patients, enjoying his Land Rovers, running marathons, or taking his red tail hawk Ajax out for a flight, Tim Lepore finds his Land Rovers the perfect partners for his island life. Remember to wave hello if you come to Nantucket! 





Runaway American Dream

VILLANOVA

968 ZRT

LAND - ROYER

LAND - ROYER



457 XPB





B Back in 2009 a small convoy of Land Rovers headed off to the Solihull Society's National Rally in Leadville, CO. The enthusiasts had so much fun traveling together that they felt inspired to create a "Rover experience." That day they gave birth to the Arkansas Rover Society (ARS). It's a low key group with a simple mission: "to bring together other enthusiasts to join in the adventure and diversity of owning a Land Rover." Indeed their Rovers are as diverse as their ages and backgrounds.

The club certainly grew quickly—98 Land Rover fans in 47 Land Rovers attended the Spring Rally in March. Once again, the event took place at the Superlift Off-Road Vehicle Park in Hot Springs, AR. Hill climbs, mud pits, rock gardens, and water crossings await the off-road enthusiast, with all trails mapped and posted with difficulty ratings. You always know your location and what to expect in terms of the terrain.

My drive of about 250 miles from Texas to Arkansas paled in comparison with Josh Gilbert's convoy from the San Antonio area; the 10-hour drive earned them the long-distance award. Enthusiasts from Tennessee, Mississippi, and Louisiana also joined their Razorback friends at the rally. The Rovers present represented a nice range of Land Rover's outstanding vehicles: Range Rover Classics [including a fabulous Great Divide model], P-38's, Sports, Discovery 1's, 11's, and LR3-4's, even two Defender 90's.

Running Deep In Arkansas

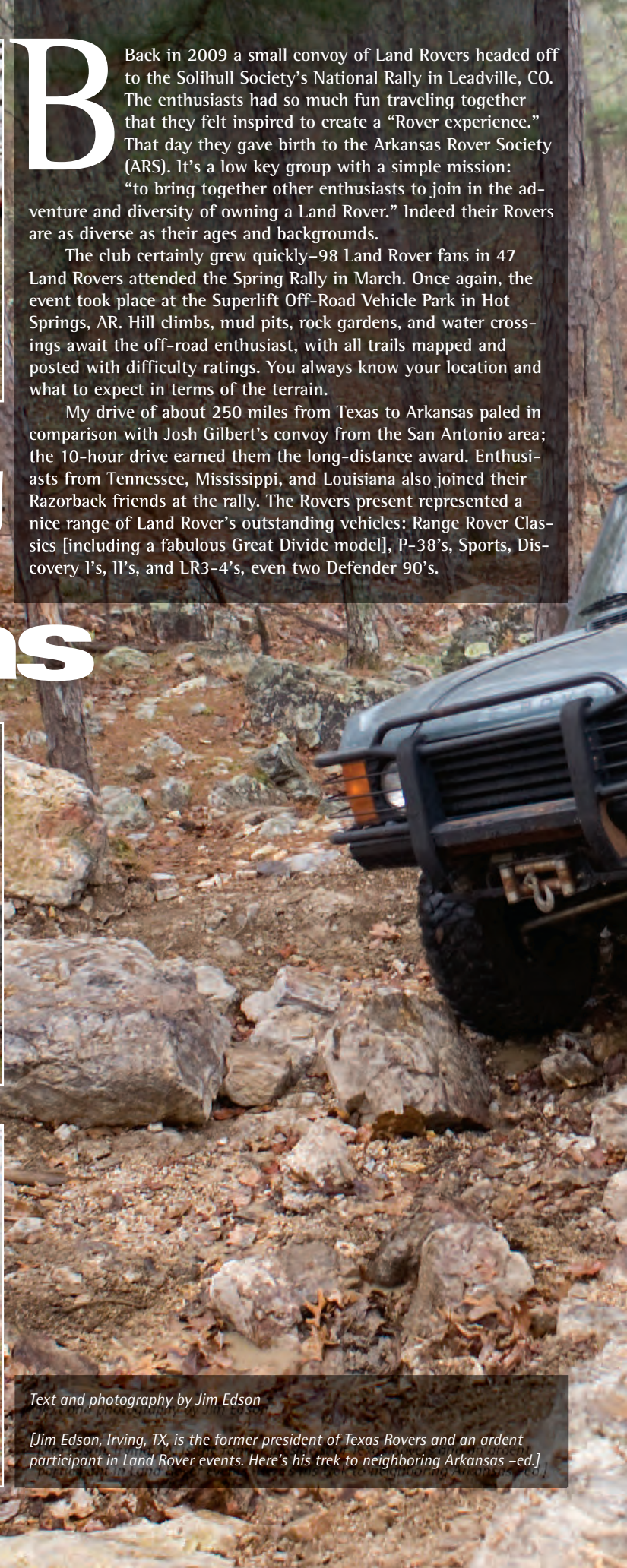

Text and photography by Jim Edson

[Jim Edson, Irving, TX, is the former president of Texas Rovers and an ardent participant in Land Rover events. Here's his trek to neighboring Arkansas -ed.]

ARKANSAS Rover Society

Watching the Land Rovers pour into the off-road park proved so compelling that we all dove into the terrific lunch provided by Nigel's Car Place, a Land Rover shop in Jacksonville, AR. Once satiated the off-roading began with convoys determined by trail difficulty rating. I joined the "low impact" group and enjoyed the "Power Wagon Point" trail. Others chose more challenging runs—for drivers and vehicles. The crazy souls who don't mind mud in every crack and cranny decided to play in the mud hole. Well every thing went well until Nigel Jebb's engine got too wet and required a tow out and a clean up. The most hyped-up folks chose The Fun Run, a three-rated trail, with narrow steep climbs, slick rock and loose rock. By then it was time to call it a day.

Saturday night the heater in my Casita Camper kicked on several times. Campers woke up to misty rain and temperatures in the low 40's. Anxious off-roaders gathered at the pavilion to start their day pumped up with caffeine and sugar (coffee and donuts) along with the obligatory (and entertaining) drivers' meeting held by Nigel. Then everyone headed off to the trails. I decided to ride shotgun with Tim Woolford, the trail leader for the "Mad Hatter" group in his highly modified classic. We drove the "Ultimate Adventures Trail". Best described as wet and rocky, best tackled with big tires and air lockers, the Superlift staff rates it as a 4. We then cut over to "Wrangler Rocks" for some more big rock and hill challenges. Tim broke a rear axle and impressed everyone with an under seven-minute axle swap. The teamwork on this emergency pit stop would make NASCAR crews envious—it certainly dazzled the Toyota and Jeepsers watching the Land Rover action.

After a fine lunch of fried chicken with all the fixings, we shared quick lies, commented on repairs done and headed out for more trail runs. I chose to ride with Tim's group again; trail names such as "Bilstein Ravine" and "Buck Horn North" hint at why rock sliders and sill protection were highly recommended. We enjoyed the challenges of "wheel off" driving and cross axle gullies.

That night, tired yet happy, I had just enough time to clean up to enjoy the delicious Arkansas BBQ dinner. Several sponsors, including Rovers North, provided items for a thrilling raffle. Overall, the ARS outdid themselves. Perhaps the finest summation of the weekend came from a new enthusiast named Mark, of Sherwood, AR. He noted "I had been talking to Nigel about getting a Land Rover. Nigel said 'Come up to Superlift and we will impress you with what they can do.' I am impressed!"



Traveling Like It's 1964

By: John Moody

[John Moody, Asheville, NC, recalls his African childhood in Rhodesia and South Africa -ed.]

1964 Sani Pass Climb

Decades ago I was born in Bulawayo, Rhodesia, of parents who had emigrated there from England. Rhodesia has since become Zimbabwe and despite its problems the remarkable land still has a firm hold on me.

Early in my childhood my father became a leader in the lightweight RV industry, (caravans as we called them) near Durbin, South Africa. His passion for the outdoors provided the impetus for becoming the S.A. outlet for Sprite Caravans. To this day I meet South Africans who claim that one of Dad's caravans introduced them to the joys of caravanning and the beauties of Africa.

Dad insisted that every new Sprite Caravan model be put through rigorous tests to ensure strength and durability. In 1964 he towed a Sprite behind a Series I Land Rover through Sani Pass, a spectacular but treacherous mountain route between South Africa and Lesotho. After ascending the last bend of Sani Pass, 9,400 feet above sea level, the rig went to the top of the Black Mountains at 10,800 feet and down again. The grade was so steep that two of the crew rode on the bonnet of the Land Rover to keep traction on the front wheels. Dad knew that if his caravan could withstand the rigors of Sani Pass he had a good product. Given the popularity of the Sprite caravan in Africa and in the UK, it's clear that he was right.

I've never forgot my father's lessons with Land Rovers; indeed my favorite car today is my 1969 Series II-A, a joy to drive despite its bumpy ride and chilly wintertime interior. During our snowiest winter days, it's often just the snow plows, the Landy and me braving the tricky mountain roads around Asheville.

I'm lucky to live in Asheville but luckier still to return to Africa annually for my safari business. I'm passionate about Africa, a continent so rich and diverse that I return to the US slightly bewildered by the incredible experiences I've had in this kaleidoscope of wonderful people, majestic wildlife and gorgeous landscapes. And I realize anew each time how fortunate I am to have first experienced all these emotions as a kid in a Landy and a Sprite Caravan.

I'm now involved with Game Plan Africa, a tour operator company specializing in custom photographic safaris to southern and eastern Africa. Planning trips for clients to Africa brings me great joy as I recall the many days I have spent on safari,

Sani Pass





Above: John Moody's three "Rovers".
 Left: John Moody and his 1969 Land Rover Series II



slowly sinking into the swamps of the Okavango Delta in Botswana, or traveling the black cottony soil of the Kruger National Park or climbing up a vertical hill in Zambia. The intrepid Land Rovers take it all in stride, giving their passengers a thrill while performing their job with perfection.

[For more information visit www.gameplanafrica.com, or contact the author directly at johnafrica@mac.com.] 



Above wedding photograph:
Lightly Photography by Sarah Rzy
Fort Worth, TX
lightlyphoto.com

Text and Photography by Jim Edson

[Jim Edson, Irving, TX, maintains GreenRovers.com and is the past president on Texas Rovers. He shares his observations on the 2011 SCARR -ed.]

The Royal Rovers

S SCARR (South Central Area Rover Rally) started with a couple of Texas Rovers members in Dallas / Fort Worth who wanted to off road with folks from Houston and Oklahoma. The gathering quickly grew into the highly anticipated South Central Area Rover Rally. I couldn't wait for this year's event.

For the second year we met up at the Hidden Falls Adventure Park, a 3,000 acre private off road facility in Marble Falls, TX, in the heart of the Texas hill country. The 22 different trails – totalling over 200 miles – offer challenging runs for all Rovers, from stock to highly modified vehicles. Indeed, trails categorized as “3 -6” required 33” + tires, air lockers, and a fearlessness about doing any damage to your Land Rover. If that's not your thing, the higher-rated trails offered bypasses from which you could observe those challenging venues.

Among the 100 entries this year were teens from the UK's League of Ventures Search and Rescue organization, led by Sir “Tiffany” Pierce-Smith, who included attending SCARR as part of their annual team building and experiential learning trek with their Defender 130. These emergency rescue volunteers-in-training would continue on through Utah and California before returning to the UK.

SCARR also featured its own “Royal Wedding” as Tami Sutherland and Dan Chapman held their wedding at the event. Naturally, they arrived at the event in their Land Rovers, and Land Rovers were pressed into service as transportation of the guests to this posh, outdoor ceremony.

SCARR RALLY 2011

It has been dry in Texas this year so off roaders had little mud or water to traverse but the challenging hill climbs, rocky approaches and stunning vistas made the two days of driving highly entertaining. We were also treating to an excellent winching training, recovering an overturned Discovery II, a fine BBQ featuring a great '80's cover band from Austin, “The Spazzmatics,” and a raffle benefiting “Wheelers for the Wounded.”

The thrilling off road opportunities, the amazing collection of old and new Land Rovers, and the terrific people all combined to make SCARR one of the nation's premier off road weekend events. Congratulations to the organizers for their dedication and hard work – I'll be back in 2012! 

Engine Air Filters

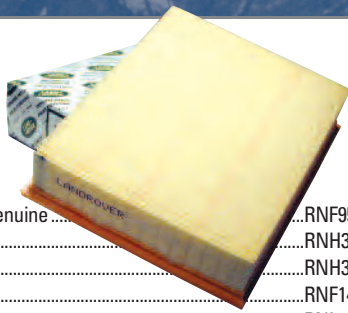

Defender NAS 90,110 V8, Genuine	RNF950	\$ 11.99
200 Tdi diesel, Genuine.....	RNH382	\$ 29.35
300 Tdi diesel, Genuine.....	RNH383	\$ 29.50
Td5 diesel, Genuine.....	RNF147	\$ 17.95
2.4 TDCi diesel, Genuine.....	RNI725	\$ 49.95
V8 Discovery I 1994-1999, Genuine	RNF010	\$ 11.95
V8 Discovery II 2000-2004, Genuine.....	RNF147	\$ 17.95
V8 Range Rover Classic 1974-1995		
1974-1985, (2 req), Genuine.....	RNF012	\$ 9.95
1986-1994, Genuine.....	RNF950	\$ 11.99
RRC 1995, Genuine.....	RNF010	\$ 11.95
V8 Range Rover P38A 1995-2002		
1995-1997, Genuine.....	RNF011	\$ 16.95
1998-2002, Genuine.....	RNF147	\$ 17.95
4.4, 4.2 Litre Range Rover L322 2003-2010		
2003-2005, 4.4 Litre, Genuine.....	RNI335	\$ 63.48
2003-2005, 4.4 Litre, ProLine.....	PLI335	\$ 37.95
2006-2010, 4.4 NA, 4.2 Litre Supercharged, Genuine.....	RNI548	\$ 50.67
2006-2010, 4.4 NA, 4.2 Litre Supercharged, ProLine.....	PLI548	\$ 29.95
V8, V6 LR3 2004-2009, Genuine	RNI346	\$ 31.95
LR2 2008-2010, Genuine	RNI719	\$ 23.25

Genuine Pollen Air Filters

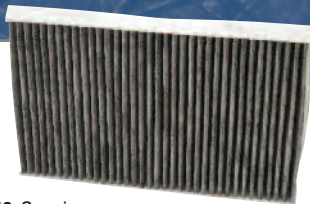

RNI353

Range Rover L322 2002-2010, Genuine	RNI392	\$ 46.20
Range Rover P38A 1996-2002, Genuine.....	RND208	\$ 26.88
LR2, Genuine	RNI723	\$ 25.84
LR3 2004-2009, Genuine	RNI353	\$ 59.00

Automatic Transmission Service Kits



Includes filter, pan gasket and O-rings
Discovery I, II, Range Rover Classic, Range Rover P38A, 1997 Defender.

ZF Trans Filter Kit, 1987-2004, Genuine	RNK312	\$ 109.00
ZF Trans Filter Service Kit, 1987-2004, ProLine	PLK312	\$ 27.50

Genuine Hub Seal Kits

Includes Genuine hub seal, hub gasket, hub seal race and locker for hub nut.

Series II, IIA, & III		
(4 req), Genuine.....	RNK552	\$ 24.39
Defender 90/110 1993-1997		
(4 req), Genuine.....	RNK5623	\$ 10.50
Discovery I 1994-1999		
Hub Seal Kit (4 req), Genuine.....	RNK5623	\$ 10.50
Range Rover Classic		
1987-'89, Hub Seal Kit (4 req), Genuine.....	RNK5621	\$ 37.90
1990-'92, Hub Seal Kit (4 req), Genuine.....	RNK5622	\$ 10.50
1993-'95, Hub Seal Kit (4 req), Genuine.....	RNK5623	\$ 10.50



Oil Filters

V8 Range Rover Classic, Range Rover P38A, V8 Discovery I & II, Defender 2.5, 3.9, 4.0 petrol, 2.5 diesel, 200, 300 Tdi,

Genuine.....	RNF001	\$ 12.95
ProLine.....	PLF001	\$ 6.29

V8 Extra Capacity, Purolator.....

.....	PLI775	\$ 6.99
-------	--------	---------

V8 Range Rover, L322, 2003-2005

w/ BMW engine, Genuine.....

V8 4.3 litre, 4.4 litre LR3, LR4,

Range Rover, 2005 on, Genuine.....

V6 LR3, Genuine.....

6 Cylinder LR2, 2008-2010, Genuine.....

6 Cylinder 2.6 litre NADA 109", petrol, Genuine.....

6 Cylinder 2.5 litre Freelander, petrol, Genuine.....

5 Cylinder 2.5 litre Td5 diesel, engine oil, Genuine.....

5 Cylinder 2.5 litre Td5, Centrifuge element, Genuine.....

4 Cylinder 2.3, 2.5 litre Defender 90/110, petrol, Genuine.....

4 Cylinder 2.4 TDCi 2007-2010, Genuine.....

4 Cylinder 2.5, 2.5 turbo, 200 Tdi, 300 Tdi diesel, Genuine.....

4 Cylinder 2.25 litre Series IIA, III, petrol / diesel, 5.5" canister, Genuine.....

4 Cylinder 2.25 litre Series IIA, III, petrol / diesel, 5.5" canister, ProLine.....

4 Cylinder 2.25 litre Series IIA, III, petrol / diesel, 7.5" canister, Genuine.....

4 Cylinder 2.25 litre Series IIA, III, petrol / diesel, 7.5" canister, ProLine.....

4 Cylinder 2.0 litre Series I, petrol, Genuine.....

.....RNE589 \$ 7.99

.....RNE590 \$ 8.50

.....RNE589 \$ 7.99

.....RNE591 \$ 8.50

.....RNE591 \$ 8.50

.....RNE591 \$ 8.50

.....RNE591 \$ 8.50

.....RNE591 \$ 8.50

.....RNE591 \$ 8.50

.....RNE591 \$ 8.50

.....RNE591 \$ 8.50

.....RNE591 \$ 8.50

.....RNE591 \$ 8.50

.....RNE591 \$ 8.50

.....RNE591 \$ 8.50

.....RNE591 \$ 8.50

.....RNE591 \$ 8.50

.....RNE591 \$ 8.50

.....RNE591 \$ 8.50

.....RNE591 \$ 8.50

.....RNE591 \$ 8.50

.....RNE591 \$ 8.50

.....RNE591 \$ 8.50

.....RNE591 \$ 8.50

.....RNE591 \$ 8.50

.....RNE591 \$ 8.50

.....RNE591 \$ 8.50

.....RNE591 \$ 8.50

.....RNE591 \$ 8.50

.....RNE591 \$ 8.50

.....RNE591 \$ 8.50

.....RNE591 \$ 8.50

.....RNE591 \$ 8.50

.....RNE591 \$ 8.50

.....RNE591 \$ 8.50

.....RNE591 \$ 8.50

.....RNE591 \$ 8.50

.....RNE591 \$ 8.50

.....RNE591 \$ 8.50

.....RNE591 \$ 8.50

.....RNE591 \$ 8.50

.....RNE591 \$ 8.50

.....RNE591 \$ 8.50

.....RNE591 \$ 8.50

.....RNE591 \$ 8.50

.....RNE591 \$ 8.50

.....RNE591 \$ 8.50

Bonnet Release Cables

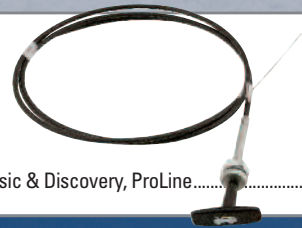

Range Rover Classic & Discovery, ProLine.....

.....PLC513 \$ 269.00

Gasket Sets & Head Gasket Sets

Includes all gaskets and seals to overhaul your cylinder head(s).

V8, 3.5 Steel Head Gasket & Valve Cover Gasket, ProLine.....

.....PLM015 \$ 79.00

V8, 3.9, 4.0, 4.2 litre, Latest OEM upgrade kit with composite head gasket and rubber valve cover gaskets, ProLine.....

.....PLM083 \$ 129.00

6 Cylinder 2.6 Petrol, ProLine.....

.....PLE602 \$ 49.99

4 Cylinder 2.25 Diesel, ProLine.....

.....PLF309 \$ 29.50

4 Cylinder 300 Tdi, ProLine.....

.....PLH701 \$ 99.50

Block Gasket Set

Includes gaskets and sealing washers used in your block and front cover.

All V8 does not include crank shaft oil seals, ProLine.....

.....PLF311 \$ 32.50

4 Cylinder 300 Tdi, does not include crank shaft oil seals, ProLine.....

.....PLH702 \$ 49.50

Full Engine Gasket Sets

Includes all gaskets and seals to overhaul your entire engine.

4 Cylinder 2.25 Petrol, ProLine.....

.....PLF308 \$ 39.99

4 Cylinder 2.25 Diesel, ProLine.....

.....PLC239 \$ 29.80

4 Cylinder 200 Tdi, ProLine.....

.....PLH703 \$ 45.50

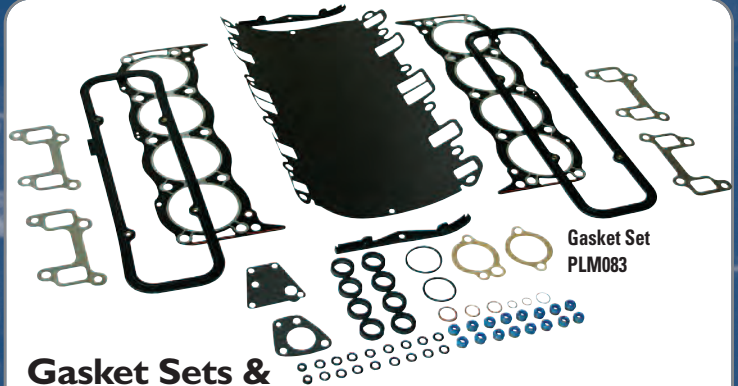

Gasket Set
PLM083

Mechanical Fuel Pumps

Series II, IIA, III gasket included

2.25 Litre, Petrol, ProLine.....	PLC349	\$ 39.50
2.25 Litre, Diesel, ProLine.....	PLF299	\$ 59.98
Defender		
200 Tdi diesel, ProLine.....	PLI739	\$ 32.68
300 Tdi diesel, ProLine.....	PLI695	\$ 39.95

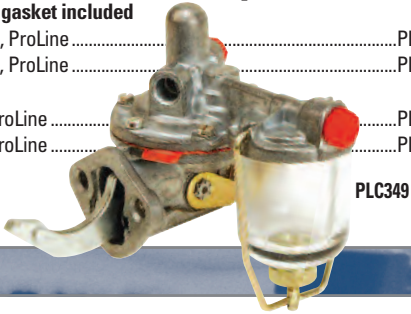

PLC349

Fuel Tanks



PLE114



Series 88" and 109" Regular, Petrol & Diesel, ProLine.....	PLC362	\$ 169.00
Range Rover Classic 1971-1985 style, ProLine.....	PLH515	\$ 249.00
Defender 110 NAS, Range Rover Classic 1987-1991, ProLine.....	PLE114	\$ 199.00
Cradle for PLE114, ProLine.....	PLE116	\$ 79.50
Series III 109", Rear Steel Fuel Tank, ProLine.....	PLH650	\$ 264.00
Fuel Sender for PLH650, ProLine.....	PLH652	\$ 47.50
Locking ring for sender, Series III, Defender 110, Range Rover Classic, Genuine.....		
	RNC886	\$ 4.99
Sealing ring for sender, Series III, Defender 110, Range Rover Classic, Genuine.....		
	RNC887	\$ 2.95
Military / Auxiliary Tank, ProLine.....	PLF360	\$ 399.00
Defender 110 Diesel up to 1999, Rear Steel Fuel Tank.....	PLN180	\$ 239.00

V8 Fuel Pumps with Fuel Sending Unit

Range Rover Classic

Fuel Pump Range Rover Classic 1987-1990, Genuine.....	RNF131	\$ 379.00
Fuel Pump Range Rover Classic 1987-1990, ProLine.....	PLF131	\$ 98.20
Fuel Pump Range Rover Classic 1991-1995, Genuine.....	RNF132	\$ 244.50
Fuel Pump Range Rover Classic 1991-1995, ProLine.....	PLF132	\$ 99.50
Fuel Sender, Range Rover Classic, Genuine.....	RND035	\$ 69.80

Defender

Defender 90, 1994-1997, Rear Tank NAS, Genuine.....	RNE131	\$ 329.00
Defender 90, 1984-1993, Side Tank, ProLine.....	PLI774	\$ 39.98
Defender 110, up to 1998, Genuine.....	RNC854	\$ 109.84

Discovery I, II

Fuel Pump Discovery I 1994-1997, Genuine.....	RNF132	\$ 244.50
Fuel Pump Discovery I 1994-1997, ProLine.....	PLF132	\$ 99.50
Fuel Pump Discovery I, II 1997-2004, from VA737154, Genuine.....	RNF148	\$ 499.00
Fuel Pump Discovery I, II 1997-2004, from VA737154, ProLine.....	PLF148	\$ 399.00

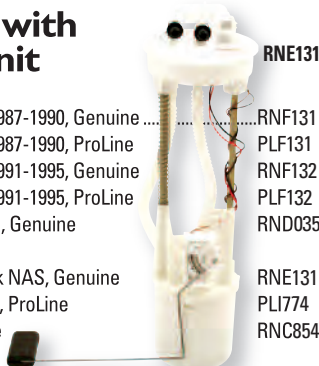

RNE131



Weber 341CH



PLC180 Solex Rebuild Kit



Reproduction Zenith PLC959

Replacement Carburetors

Weber, Series IIA & III 2.25 Litre.....	341CH	\$ 239.00
Reproduction Zenith, Series IIA & III 2.25 Litre.....	PLC959	\$ 169.00

Carburetor Rebuild Kits

Zenith 1967-1983 Series IIA-III, 2.25 Rebuild Kit.....	PLC622	\$ 24.95
Weber 341CH Rebuild kit.....	WEBERKIT	\$ 29.60
Solex 1959-1966 Series II-IIA Rebuild kit.....	PLC180	\$ 31.49

Fuel Filters

Series II, IIA, III 1959-1976

Inline filter with Quick Clamp		
Fittings, that can be adapted to any 5/16" fuel line, ProLine.....	RFF111	\$ 6.45
Series III 1974 on, 2.25 litre petrol, canister type, Genuine.....	RNE235	\$ 5.90

Defender 90/110 1993-1997

V8 inline with threaded fittings, Genuine.....	RNF861	\$ 22.99
V8 inline with threaded fittings, ProLine.....	PLF861	\$ 5.95
2.25, 2.5 petrol, inline w/threaded fittings, Genuine.....	RNC632	\$ POA
2.25, 2.5 petrol, inline, splice in, ProLine.....	RFF111	\$ 6.45
2.25, 2.5 NA, 2.5 turbo diesel, Genuine.....	RNC745	\$ 8.35
200, 300Tdi Fuel Filter-diesel, Genuine.....	RNF862	\$ 24.50
200, 300Tdi Fuel Filter-diesel, ProLine.....	PLF862	\$ 7.90
Td5, Fuel Filter, Genuine.....	RND270	\$ 59.95
2.4 TDCi, 2007-2010, Genuine.....	RNI724	\$ 49.80

Discovery I 1994-1999

V8, threaded both ends, Genuine.....	RNF861	\$ 22.99
V8 inline with threaded fittings, ProLine.....	PLF861	\$ 5.95

Range Rover Classic 1987-1995

Fuel Filter Update Kit (required for early V8 Range Rover up to VIN #LA464553), Genuine.....	RNF133	\$ 74.50
---	--------	----------

Range Rover Classic V8 1987-1990, fuel filter (up to

VIN #LA464553 w/out update kit).....	RNF025	\$ 14.99
Range Rover Classic V8 1987-1995 (threaded both ends), Genuine.....	RNF861	\$ 22.99
Range Rover Classic V8 1987-1995, ProLine.....	PLF861	\$ 5.95

Fuel Caps

Defender, Discovery I, II, ProLine.....	PLF143	\$ 12.95
Series II & IIA, ProLine.....	PLC168	\$ 8.93
Series III, ProLine.....	PLE406	\$ 11.03



RNF861

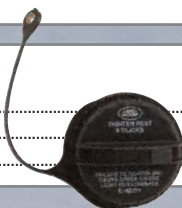

PLC168



Discovery II V8
RNK9302



Defender 300 TDI
RNK0001

SAVE!

Basic Engine Service Kits

V8 Kits Include: Oil Filter, Oil sump drain washer

V8 - Range Rover, Defender	RNK9300	\$ 15.50
V8 - Discovery I	RNK9301	\$ 15.40
V8 - Discovery II	RNK9302	\$ 14.30

Defender 300 TDI Kit includes: Air Filter, Oil Filter and Fuel Filter 300 TDI Filter Change Kit.....RNK0001 \$ 49.99

NEW Alternators & Generator

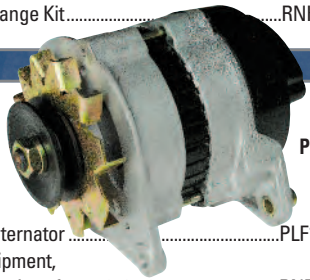

PLF193

Series III 12 Volt Lucas Style Alternator.....PLF193 \$ 99.50

Series Generator, Original Equipment, all 2.25 Litre petrol and diesel engines from 1959-1971.....RNE647 \$ 129.00

Series Alternator Conversion Mounting Kit, Converts Generator to Alternator Includes proper brackets and instructions.....RNK951 \$ 272.94

Defender 2.5 NA Diesel, 2.5 Turbo Diesel, 200 TDI, 2.5 Petrol, 3.5 V8.....PLD498 \$ 199.00

300 TDI, 65 AMP, Defender 90, 110.....PLH259 \$ 239.00

3.9 Litre V8, Defender 90/110 NAS.....PLE846 \$ 229.00

4.0 Litre V8, Defender 90 NAS 1997.....PLE870 \$ 299.95

Discovery I 4.0 litre 1996-1999.....PLE870 \$ 299.95

Discovery I 3.9 litre, 1994-1995, 67mm, 7 groove pulley for serp belt.....PLE863 \$ 299.95

Range Rover Classic, 1987-'88.....PLD498 \$ 199.00

Range Rover Classic, 1993-'94, 100 amp 4 groove pulley.....PLE846 \$ 229.00

RRC, from SA647650, 52mm, 7 groove pulley for serp belt.....PLE870 \$ 299.95

Range Rover P38A from VA346795 to WA410481, 120 AMP, 52mm, 7 Groove Pulley.....PLE870 \$ 299.95



PLI533

2.25 & 2.6 L
Petrol
Hi-Torque
Starter
PLI029

NEW Starter Motor Assemblies

V8 Early.....PLI533 \$ 189.00

V8 thru 2004, except Range Rover thru 2002.....PLE867 \$ 219.00

2.25 & 2.6, Litre petrol.....RNF197 \$ 269.00

2.25 & 2.6, Litre petrol, Hi-Torque, ProLine.....PLI029 \$ 289.00

2.25, Diesel.....PLF198 \$ 239.00

200 & 300 Tdi, High speed.....PLD294 \$ 439.00

Td5, Defender & Discovery.....PLI728 \$ 359.00



RNK9330
1987-'90 Range Rover Classic
30K Mile Service Kit

Complete 30K Mile Engine Service Kits

Range Rover Classic

30K Mile Service Kit, Range Rover Classic 1987-'90.....RNK9330 \$ 339.00

30K Mile Service Kit, Range Rover Classic 1991-'94.....RNK9331 \$ 339.00

Discovery I

30K Mile Service Kit, Discovery I 1994-'95 Automatic.....RNK9332 \$ 299.99

30K Mile Service Kit, Discovery I Standard Transmission.....RNK9333 \$ 205.28



RNK9337

**Improve your mpg!
Engine Ignition Service Kits**

Ignition Tune-Up Kit, 3.5, 3.9, 4.2 L V8, RRC, Defender.....RNK9335 \$ 198.00

Ignition Tune-Up Kit, Range Rover Classic, 1995.....RNK9337 \$ 236.25

Ignition Tune-Up Kit, V8, 3.9 L, 1994-'95 Discovery I.....RNK9336 \$ 157.45

Ignition Tune-Up Kit, V8, 4.0 L, 1996-'99 Discovery I.....RNK9339 \$ 149.00

Ignition Tune-Up Kit, V8, 1995-'98, RR P38A.....RNK9340 \$ 139.00

Ignition Tune-Up Kit, V8, 1999 on, RR P38A, Discovery II.....RNK9341 \$ 289.00

Ignition Coil



RNE509

4 Cylinder and 6 Cylinder.....RNE522 \$ 99.95

3.9 litre and 4.2 litre

Bosch ignition coil for EFI.....RNE509 \$ 144.80

Spark Plugs

RRC, Discovery I, Defender, Range Rover P38A, Genuine.....RNI003 \$ 5.99

RRC, Discovery I, Defender, Range Rover P38A, NGK.....PLI003 \$ 2.84

RRC, Discovery I, Defender, Range Rover P38A, Champion.....PLI003C \$ 3.99

Platinum - Discovery II, Range Rover P38A, Bosch.....RNI034 \$ 13.65

2.25 Petrol 8:1 W7DC.....RNE630 \$ 2.59

2.25 Petrol 7:1 W8CC.....RNE619 \$ 2.59

2.6 litre.....RNE631 \$ 3.99

Range Rover L322.....RNI360 \$ 10.99



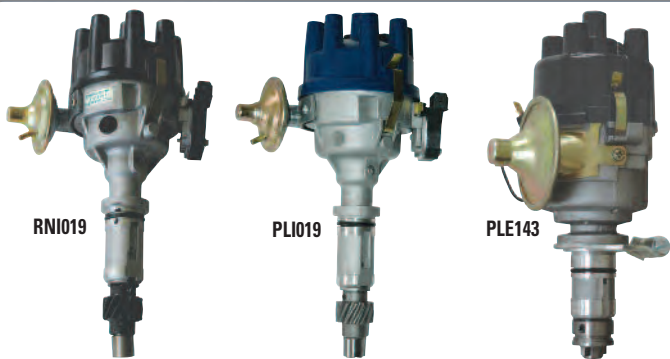

NEW Complete Distributor Assemblies

V8 EFI Distributor Assembly 3.5, 3.9, 4.2, Genuine	RNI019	\$ 699.00
V8 EFI Distributor Assembly 3.5, 3.9, 4.2, ProLine	PLI019	\$ 239.00
Series II, IIA & III 2.25L 4 Cylinder models, ProLine	PLE143	\$ 119.00
V8 Module Amplifier, 3 Pin, ProLine	PLI024	\$ 73.45
V8 Vacuum Unit, ProLine	PLI009	\$ 79.45

Ignition Condenser

Series 2.25 litre

Early Lucas	RNE613	\$ 4.87
Late Lucas, red or blue point sets	RNF229	\$ 5.23
Ducellier type	PLF228	\$ 2.42
2.6 litre 6 Cylinder, 3.5 litre V8	RNE613	\$ 4.87

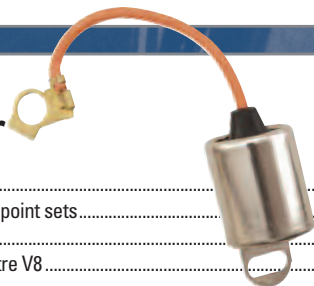

Ignition Point Sets

4 Cylinder and 6 Cylinder Early Lucas Points

Condenser and low tension lead ends slide over the round post and are "Sandwiched" between the points spring and plastic isolator. A single nut tightens these on the post

4 Cylinder Late Lucas (red)

Combination low tension / condenser lead clips onto the "Shepard Hook" end of the points spring

4 Cylinder Late Lucas (blue)

Similar as preceding, but blue. Known as sliding points

4 Cylinder Ducellier

Two-piece points. Low tension lead attached by moving contact. Condenser mounted on outside of distributor

24 volt FFR (Fitted for Radio)

Points set Military 2.25 litre (not pictured)

V8 3.5 Litre

Sliding point set

Non-sliding point set



RNE595



RNE637



RNF232



RNF231



PLI738



RND074

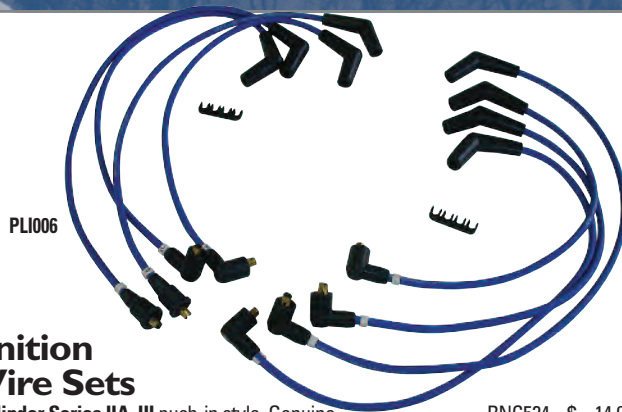

Ignition Wire Sets

4 Cylinder Series IIA, III push-in style, Genuine	RNC524	\$ 14.95
4 Cylinder Series III push-in style, ProLine	PLC960	\$ 12.99
4 Cylinder Series III push-in style, Lucas	PLC960L	\$ 19.50
V8, 3.5, 3.9 litre, Genuine	RNI004	\$ 69.95
V8, 3.5, 3.9 litre, ProLine	PLI004	\$ 29.95
V8, 4.2 litre 1995 Range Rover Classic LWB, Genuine	RNI005	\$ 119.00
V8, Gems, 4.0 litre, 1995-1999, Discovery I, Range Rover P38A, Defender 4.0, Genuine	RNI006	\$ 99.80
V8, Gems, 4.0 litre, 1995-1999, Discovery I, Range Rover P38A, Defender 4.0, ProLine	PLI006	\$ 49.50
V8, Bosch 1999-2004, Range Rover P38A, Discovery II, Genuine	RNI007	\$ 187.95
V8, Bosch 1999-2004, Range Rover P38A, Discovery II, ProLine	PLI007	\$ 43.50

Distributor Caps

Sold separately

1. 4 Cylinder Series II, IIA with screw-in wire ends, Genuine	RNC603	\$ 26.50
2. 4 Cylinder Series IIA, III Early Lucas, push-in, ProLine	PLC437	\$ 11.75
3. 4 Cylinder Late Lucas, Genuine	RNE596	\$ 15.99
4 Cylinder Late Lucas, ProLine	PLE596	\$ 6.90
4. 4 Cylinder Ducellier Type Cap, ProLine	PLF185	\$ 7.90
4 Cylinder Military 24 volt FFR, Genuine	RNC767	\$ 150.33
6 Cylinder, ProLine	PLC628	\$ 9.80
V8, Genuine	RNI001	\$ 54.50
V8, Lucas, ProLine	PLI001	\$ 18.50



1



2



3



4

Distributor Rotors

Sold separately

1,2. Early Lucas, ProLine	PLE633	\$ 5.95
3. Late Lucas, ProLine	PLE634	\$ 4.75
4. Ducellier Type Cap, Genuine	RNF186	\$ 5.90
6 Cylinder, Genuine	RNF178	\$ 4.79
V8, Genuine	RNI002	\$ 39.50
V8, ProLine	PLI002	\$ 8.50

Wiper Blades

Series IIA, III Wiper Blade, 5 mm, ProLine.....	PLD285	\$ 5.95
Series IIA, III Wiper Blade, independent wiper w/orig hook arm.....	RNE612	\$ 17.50
Defender 90, 110 , Wiper Blades, Front or Rear.....	RNC948	\$ 13.95
Defender 1993 - '97, Rear door wiper blade, Genuine.....	RNC948	\$ 13.95
Discovery I 1994-'99 , Front Wiper Blade, Genuine.....	RNW116	\$ 8.43
Discovery I 1994-'99, Front Wiper Blade with spoiler (driver's side), Genuine.....	RNW117	\$ 9.26
Discovery I 1994-'99, Rear Wiper Blade, Genuine.....	RNW103	\$ 13.30
Discovery I 1994-'99, Rear Winter Blade, ProLine.....	RNF166	\$ 17.80
Discovery II 1999-'04 , Front Wiper Blade, Genuine.....	RNW113	\$ 21.95
Discovery II 1999-'04, Front Winter Blades (Pair), Genuine.....	RNH876	\$ 72.43
Discovery II 1999-'04, Rear Wiper Blade, Genuine.....	RNW100	\$ 12.95
RR Classic 1987-'89 , Front or Rear Wiper Blade, Genuine.....	PLW104	\$ 6.95
RR Classic 1990 -'95, Front or Rear Wiper Blade, Genuine.....	RNW111	\$ 14.50
RR P38A 1995-'02 , Front Wiper Blade, Genuine.....	RNW107	\$ 19.95
RR P38A 1995-'02, Front Wiper Blade, ProLine.....	PLW107	\$ 10.95
RR P38A 1995-'02, Rear Wiper Blade, Genuine.....	RNW118	\$ 15.95
RR P38A 1995-'02, Headlamp Wiper Blade.....	RND223	\$ 14.66
RR L322, 2002-'09 , Front Wiper Blade, Genuine.....	RNH780	\$ 22.50
RR L322, 2002-'09, Front Wiper Blade, ProLine.....	PLH780	\$ 12.95
RR L322, 2002-'09, Rear Wiper Blade, Genuine.....	RNI126	\$ 36.22
RR L322, 2002-'09, Rear Wiper Blade, ProLine.....	PLI126	\$ 12.95
RR Sport, 2005-'09 , Front Wiper Blade, Genuine.....	RNH781	\$ 28.95
RR Sport, 2005-'09, Front Wiper Blade, ProLine.....	PLH781	\$ 19.95
RR Sport, 2005-'09, Rear Wiper Blade, Genuine.....	RNI747	\$ 39.89
LR3, 2008-'10 , Front Wiper Blade, Genuine.....	RNH781	\$ 28.95
LR3, 2008-'10, Front Wiper Blade, ProLine.....	PLH781	\$ 19.95
LR3, 2008-'10, Rear Wiper Blade, Genuine.....	RNI355	\$ 16.17
LR2, 2008-'10 , Front Wiper Blade, Drivers side, Genuine.....	RNI742	\$ 22.95
LR2, 2008-'10, Front Wiper Blade, Passenger side, Genuine.....	RNI743	\$ 26.95
LR2, 2008-'10, Rear Wiper Blade, Genuine.....	RNI744	\$ 17.50



Drive Shafts

Discovery I Rear Drive Shaft Update Kit replaces Flex Coupler Drive Shaft with Twin U-Joint type. Includes new rear Drive Shaft and 4 bolt Differential Flange kit, ProLine.....PLK4100 \$ 269.00



PLD665

New Drive Shaft Assemblies with U-Joints

Series II, IIA, III, front, 88 & 109, ProLine.....	PLF315	\$ 159.95
Series II, IIA, III 88, rear, ProLine.....	PLE189	\$ 178.45
Series II, IIA 109, rear, ProLine.....	PLF358	\$ 178.45
Defender 90 V8 , rear, ProLine.....	PLE201	\$ 199.00
Defender 110, front, ProLine.....	PLF410	\$ 268.00
Defender 110, 4 Cyl up to 1999, rear, ProLine.....	PLE217	\$ 251.95
Discovery II , front, 1999-2002, ProLine.....	PLD665	\$ 399.00
Discovery II, front, 2003-2004 4.6 litre, ProLine.....	PLI782	\$ 459.00
Discovery I & Range Rover Classic 100 inch, rear, ProLine.....	PLD473	\$ 199.00



ProLine

Discovery II Hub Assembly with Sensor

Discovery II 1999-2004.

Includes bearings, ABS sensor.

Front hub assembly.....	PLD676	\$ 369.00
Rear hub assembly.....	PLD694	\$ 321.00



PLD676

U-Joint Kits

Series II, IIA, III

Front & rear, 2 15/16" from cap top to cap top, Genuine.....	RNE598	\$ 44.90
Front & rear, 3 7/32" from cap top to cap top, Genuine.....	RNE604	\$ 58.24
Discovery I, Range Rover Classic Front & rear, Genuine.....	RNF411	\$ 69.00
Defender 90 Front, Genuine.....	RNF411	\$ 69.00
Rear, Genuine.....	RNE611	\$ 49.99
Defender 110 , Front or rear, Genuine.....	RNE611	\$ 49.99

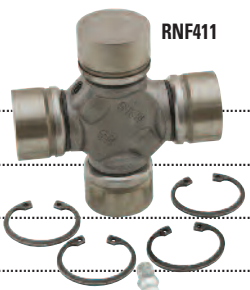

RNF411

Rear Driveshaft Flex Couplers

Range Rover Classic 1995 Discovery I & II

Flex Coupler for rear drive shaft, with hardware, Genuine.....	RND196	\$ 110.95
Flex Coupler, with hardware, OME, ProLine.....	PLD196	\$ 69.50

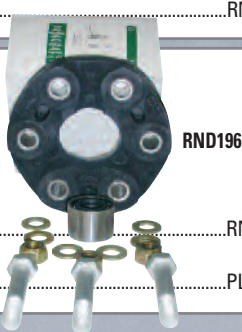

RND196

1999-'04
Discovery II RND564

Thermostats

2.25, 2.6 Petrol and Diesel Series IIA-III

Thermostat 74 C / 165 F, Genuine.....	RNC276	\$ 42.39
Thermostat 74 C / 165 F, ProLine.....	PLC276	\$ 9.95
Thermostat 82 C / 179 F, Genuine.....	RNC580	\$ 43.90
Thermostat 82 C / 179 F, ProLine.....	PLC580	\$ 8.95
Thermostat 88 C / 190 F, Genuine.....	PLC320	\$ POA
Thermostat, 2.6 Litre, Genuine.....	RNC421	\$ 16.10
V8 Discovery I, Range Rover Classic, Defender Thermostat 82 C / 179 F, Genuine.....	RNH386	\$ 14.99
Thermostat 82 C / 179 F, ProLine.....	PLH386	\$ 4.74
Thermostat 88 C / 190 F, Genuine.....	RNC047	\$ 10.50
2.5 NA Diesel Defender , Thermostat 75°C / 165 F.....	RNL151	\$ 21.80
2.5 NA Diesel Defender, Thermostat 82°C / 179 F.....	RNH386	\$ 14.99

Thermostat Assemblies

V6 Freelander Thermostat assembly.....	RNL472	\$ 92.72
V8 Discovery II 1999-2004 Thermostat assembly, Genuine.....	RND564	\$ 39.91
Thermostat assembly, ProLine.....	PLD564	\$ 23.50
V8 Range Rover P38A 1995-2002 Thermostat assembly, Genuine.....	RND564	\$ 39.91
Thermostat assembly, ProLine.....	PLD564	\$ 39.91

V8 Range Rover L322 2003-2010

4.4ltr. 2003-'05, BMW Engine, thermostat assembly, Genuine.....	RNJ993	\$ 153.21
4.4, 4.2ltr. Supercharged, 2006-'09 thermostat assembly, Genuine.....	RNJ330	\$ 35.78
4.4ltr., O-ring seal, thermostat housing, Genuine.....	RNN217	\$ 5.66

Thermostat Gaskets 2.25 Petrol and Diesel Series IIA-III

Top thermostat gasket, ProLine.....	PLC245	\$ 0.83
Top O-ring seal, Genuine.....	RNC248	\$ 1.73
Bottom thermostat gasket, ProLine.....	RNB573	\$ 3.66
Side by-pass gasket, Genuine.....	RNC738	\$ 2.78
V8 Discovery I, RRC, Defender Thermostat gasket, Genuine.....	RNC046	\$ 2.61
2.5 NA Diesel Thermostat gasket, Genuine.....	RNH387	\$ 4.49
200Tdi Defender Thermostat, Genuine.....	RNL141	\$ 20.59
200Tdi Diesel Thermostat gasket, Genuine.....	RNH387	\$ 4.49
300Tdi Defender Thermostat, Genuine.....	RNL137	\$ 19.85

Thermostat Kits

2.25 Petrol Series IIA-III . Kits include o-ring, upper and lower gaskets and thermostat		
Thermostat Kit 74 C / 165 F.....	RNK1574	\$ 25.18
Thermostat Kit 74 C / 165 F.....	PLK1574	\$ 25.18
Thermostat Kit 82 C / 179 F.....	RNK1582	\$ 47.50
Thermostat Kit 82 C / 179 F.....	PLK1582	\$ 14.99
Thermostat Kit 88 C / 190 F.....	RNK1588	\$ 44.95

NEW Radiators

2.25 Litre, Series II-III 4 core style radiator requires top hose RNC510 and bottom hose PLE407 when fitting to Series II-IIA, ProLinePLC513 \$ 269.00

Discovery I 1994-1999
with automatic transmission, GenuineRNC062 \$ 699.00
3.9 Litre V8, ProLinePLC019A \$ 679.95
Plastic Fill Plug, Radiator, GenuineRNC997 \$ 2.30
Washer, For Plastic Fill Plug, GenuineRNC996 \$ 1.95

Range Rover Classic 1987-1995

1987-1988, Radiator, ProLine.....PLC020 \$ 459.00
1993-1995, Radiator, GenuineRNC062 \$ 699.00
1989-1995, Radiator, ProLine.....PLC019A \$ 679.95
Plastic Fill Plug, Radiator, GenuineRNC997 \$ 2.30
Washer, For Plastic Fill Plug, Genuine.....RNC996 \$ 1.95

Defender 1993-1997

NAS 90/110 V8 Radiator Assembly, Genuine.....RNE130 \$ 589.00
Defender 300 Tdi Radiator with intercooler, ProLinePLD500 \$ 498.00
Defender 300 Tdi Radiator, ProLinePLH255 \$ 268.00
Defender 200 Tdi Radiator, ProLinePLD496 \$ 269.00

Discovery II 1994-2004 Radiator, ProLinePLD495 \$ 279.00

Range Rover 2002 on

L322 4.4 Litre, ProLine.....PLI516 \$ 399.95

Discovery II
Radiator with
secondary air
PLD495

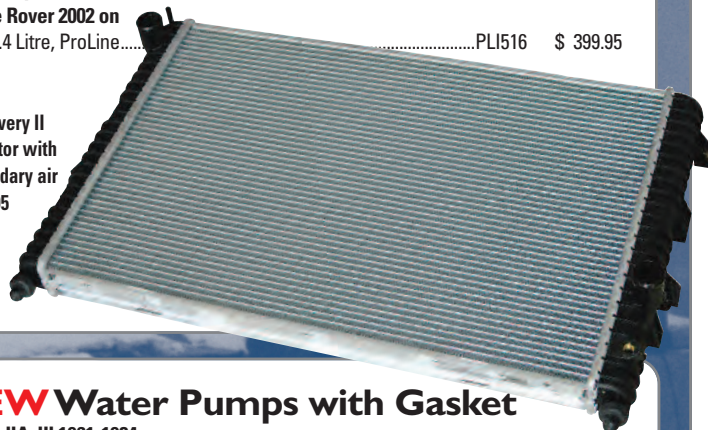

NEW Water Pumps with Gasket

Series IIA, III 1961-1984

2.25 litre petrol, diesel, GenuineRNF334 \$ 129.00
2.25 litre petrol, diesel, ProLinePLF334 \$ 49.50
Rebuild kit for 2.25 water pumpsPLE587 \$ 34.95

Defender 90/110 1993 - 2006

1993-1995 NAS, Water Pump, GenuineRNC011 \$ 239.95
'93-1995 NAS, Water Pump, ProLinePLC011 \$ 89.00
'97 D90 NAS, Water Pump, GenuineRNC052 \$ 289.00
'97 D90 NAS, Water Pump, ProLinePLC052 \$ 89.50
200 Tdi diesel, Water Pump, GenuineRNH257 \$ 249.00
200 Tdi diesel, Water Pump, ProLine.....PLH257 \$ 89.00
300 Tdi diesel, Water Pump, GenuineRNH258 \$ 128.00
Td5 diesel, Water Pump, GenuineRNH360 \$ 148.60

Discovery I 1994-1999

Water Pump, GenuineRNC052 \$ 289.00
Water Pump, ProLine.....PLC052 \$ 89.50

Discovery II 2000-2002

Water Pump, GenuineRNC052 \$ 289.00
Water Pump, ProLine.....PLC052 \$ 89.50

Range Rover Classic 1987-1995

'87-1994, Water Pump, GenuineRNC011 \$ 239.95
'87-1994, Water Pump, ProLine.....PLC011 \$ 89.00
'95, Water Pump, GenuineRNC052 \$ 289.00
'95, Water Pump, ProLine.....PLC052 \$ 89.50

Range Rover P38A 1995-2002

'95-2002, Water Pump, GenuineRNC052 \$ 289.00
'95-2002, Water Pump, ProLinePLC052 \$ 89.50

Hylomar Gasket Sealer

Official sealer used by Land Rover during assembly.

Supplied in 3.5 oz. tubesRNA681 \$ 10.95



RNK1609

Stop Leaks!

Complete Cooling System Kits

We only recommend genuine hoses. There is a dramatic difference in quality!

Includes: Genuine radiator hoses, heater hoses, expansion tank hoses, thermostat, gasket and all necessary clamps.

Range Rover Classic

Cooling System Kit, Range Rover Classic 1987-'88RNK1601 \$ 209.00
Cooling System Kit, Range Rover Classic 1989.....RNK1602 \$ 241.45
Cooling System Kit, Range Rover Classic 1990-'94.....RNK1603 \$ 299.00
Cooling System Kit, Range Rover Classic, 4.2L 1993-'94.....RNK1604 \$ 272.95
Cooling System Kit, Range Rover Classic 1995.....RNK1608 \$ 249.00

Range Rover P38A

Cooling System Kit, Range Rover P38A up to VIN XA30701RNK1610 \$ 319.95
Cooling System Kit, Range Rover P38A from VIN YA30702.....RNK1610A \$ 390.00

Discovery I

Cooling System Kit, Discovery I w/A.E.L.....RNK1607 \$ 279.00
Cooling System Kit, Discovery I w/o A.E.LRNK1606 \$ 299.00

Discovery II

Cooling System Kit, Discovery II (shown above).....RNK1609 \$ 315.95



RNK1618

Radiator Hose Kits

We recommend only using genuine hoses when it's time to replace yours. Don't settle for lower quality imitations. Includes: Genuine top and bottom radiator hoses, manifold jacket hoses, and all necessary clamps.

Range Rover Classic

Radiator Hose Kit, Range Rover Classic, 1989RNK1612 \$ 129.00
Radiator Hose Kit, Range Rover Classic, 3.9L 1990-'94.....RNK1613 \$ 149.00
Radiator Hose Kit, Range Rover Classic, 4.2L 1993-'94.....RNK1614 \$ 179.95
Radiator Hose Kit, Range Rover Classic, 4.2L 1995.....RNK1617 \$ 159.00

Range Rover P38A

Radiator Hose Kit, Range Rover P38A, up to VIN XA430701.....RNK1619 \$ 199.95
Radiator Hose Kit, Range Rover P38A, from VIN YA430702.....RNK1619A \$ 290.00

Discovery

Radiator Hose Kit, Discovery IRNK1616 \$ 169.00
Radiator Hose Kit, Discovery I w/EVAP Loss SystemRNK1618 \$ 189.00

ExmoorTrim™

Authorised Distributor

Series Interior

Available Trim and Fabric Choices

Elephant Hide Vinyl
Series Models
1959-1967

Black Vinyl
Series Models
1959-1967



More Exmoor Trim products
www.roversnorth.com/exmoor-trim

RNC128

EXT370EHG

Series Trakkers Exeme Hi-Back Seat Assembly

Direct replacement for Series II-III front driver seat.

Black Vinyl seat bottom & back w/pocket.....EX4949 Each \$ 279.00 Pair \$ 499.00

Elephant Hide seat bottom & back w/pocket

(as shown in red Series at left).....EXT370EHG Each \$ 329.00 Pair \$ 599.00



EX4949



EX6616K

Basic Black Vinyl Seats

Bottom cushion, Driver/Pass.....EX8622 \$ 68.00
Bottom cushion, Center.....EX2252 \$ 47.00
Back cushion, Driver/Pass.....EX442 \$ 84.50
Back cushion, Center.....EX2308 \$ 78.50
Front Seat Set.....EX6616K \$ 359.00



Seat Heater Kits

Sold in pairs. Includes wiring loom & Hi / Low Switches
EX9969 \$ 199.00



EX9969



EX6629

Elephant Hide Vinyl

Bottom cushion, Driver/Pass.....EX8625 \$ 79.50
Bottom cushion, Center.....EX2255 \$ 74.95
Back cushion, Driver/Pass.....EX444 \$ 108.00
Back cushion, Center.....EX2311 \$ 98.60
Front Seat Set.....EX6629 \$ 519.00

Seat belts sold separately.

Series Center Interior Tunnel Cover

Series II, IIA, III, Interior Tunnel Cover, fits 4-cyl, 2.25 liter only. Cloth
RNC128 \$ 84.95



EX844

Series Insulated Rubber Floor Mats

Series II, IIA, III, Front set.....EX844 \$ 129.00
 Series 88", Loadspace.....EXT0091 \$ 129.95



EX11645K

Deluxe Black Vinyl Seats

Bottom cushion, Driver/Pass.....EX2182 \$ 65.80
Bottom cushion, Center.....EX2196 \$ 62.50
Back cushion, Driver/Pass.....EX2168 \$ 79.50
Back cushion, Center.....EX2210 \$ 74.50
Deluxe Front Black Vinyl Set.....EX11645K \$ 399.00

Series Interior

Available Trim and Fabric Choices

Elephant Hide Vinyl
Series Models
1959-1967

Black Vinyl
Series Models
1959-1967



Rear Jump Seat

Twill Vinyl.....	EX4128	\$ 206.10
Black Vinyl.....	EX4126	\$ 197.10
Moorland.....	EX4133	\$ 206.10
Elephant Hide Vinyl.....	EX4138	\$ 229.00
Car Denim NAS.....	EX9607NAS	\$ 248.00



Middle Row Seats

For 109" and early 110 Staton Wagons fitted with 3 individual second row seats (seat belts not included). See page 25 for complete seat belt listings.

Outer High Back Seat

Outer High Back Seat, includes bottom and back, Black Vinyl.....	EXT350BV	\$ 229.00
Outer High Back Seat, includes bottom and back, Twill Vinyl.....	EXT350DT	\$ 249.00
Outer High Back Seat, includes bottom and back, Dark Grey Vinyl.....	EXT350DGV	\$ 229.00
Outer High Back Seat, includes bottom and back, Elephant Hide.....	EXT350EHG	\$ 269.00

Middle Low Back Seat

Middle Low Back Back Seat, includes bottom/back, Black Vinyl.....	EXT351BV	\$ 229.00
Middle Low Back Back Seat, includes bottom/back, Twill Vinyl.....	EXT351DT	\$ 239.00
Middle Low Back Back Seat, inc. bottom/back, Dark Grey Vinyl.....	EXT351DGV	\$ 229.00
Middle Low Back Back Seat, inc. bottom/back, Elephant Hide.....	EXT351EHG	\$ 269.00



RNA4600

ExmoorTrim™
Authorised Distributor



EX2831

Above: Middle door 109" Series IIA restored by Lanny Clark Rovers, sold by Orvis.

Series Interior Trim

Front Door Interior Trim Set, Series IIA, III, RH+LH, Black Vinyl.....	RNA4600	\$ 269.00
Front Door Interior Trim Set, Series IIA, III, RH+LH, Elephant Hide.....	EX6284	\$ 329.00
Deluxe Front Seat Black Vinyl Set, Series II, IIA, III.....	EX11645K	\$ 399.00
Middle Door Panel Upper 109", RH, Black Vinyl.....	EX2769	\$ 35.95
Middle Door Panel Upper 109", LH, Black Vinyl.....	EX2764	\$ 35.95
Middle Door Panel Upper 109", RH, Elephant Hide Vinyl.....	EX6273	\$ 47.95
Middle Door Panel Upper 109", LH, Elephant Hide Vinyl.....	EX6272	\$ 47.95
Middle Door Panel Lower 109", RH, Black Vinyl.....	EX2831	\$ 45.95
Middle Door Panel Lower 109", LH, Black Vinyl.....	EX2820	\$ 45.95
Middle Door Panel Lower 109", RH, Elephant Hide Vinyl.....	EX6281	\$ 59.95
Middle Door Panel Lower 109", LH, Elephant Hide Vinyl.....	EX6280	\$ 59.95
Insulated Rubber Floor Mat Set Front Pair, Series II, IIA, III.....	EX844	\$ 129.00
Rear Door Interior Trim, Series IIA, III, Black Vinyl.....	EX2836	\$ 54.00
Rear Door Interior Trim, Series IIA, III, Elephant Hide Vinyl.....	EX6282	\$ 76.20

Rear Seats



EX6861

Rear Side Bench Seat Kits, Series II, IIA, III

Rear Bench Seat Kit, Elephant Hide Vinyl, Galvanized Frame.....	EX6877	\$ 239.00
Rear Bench Seat Kit, Black Vinyl, Galvanized Frame.....	EX6861	\$ 199.00
Rear Bench Seat Kit, Black Vinyl, Black Frame.....	EX4198	\$ 169.00
Bottom Cushion, Black Vinyl.....	EX4527	\$ 48.20
Bottom Cushion, Elephant Hide Vinyl.....	EX5948	\$ 69.50

Pedal Pad Sets

Series II, IIA, III.....	RNK8211	\$ 28.95
Defender Manual.....	RNK8225	\$ 22.50
Defender Automatic Transmission, 1997.....	RNK8226	\$ 43.50



EX0091

EX0096

Defender Insulated Rubber Floor Mats

Series, Defender 90, Loadspace.....	EXT0091	\$ 129.95
Defender 4 Cylinder, Front Set.....	EXT0096	\$ 89.50
Defender V8, Front Set.....	EXT0097	\$ 79.95
Defender, Moulded Rubber Mat.....	EX6136	\$ 829.00

EX6136

Defender Interior

Available Trim and Fabric Choices -
Standard Defender Seats

XS Black Rack - Cloth
Center Seat Back and Sides
Black Leather

Twill Vinyl
1995 NAS Soft Top,
& 1997 Station Wagons

Dark Grey Vinyl

Car Denim Vinyl
1994 NAS Models
& 1997 Soft Tops

Moorland Cloth Faced
1993 & 1995 90/110
NAS Station Wagons

Black Leather

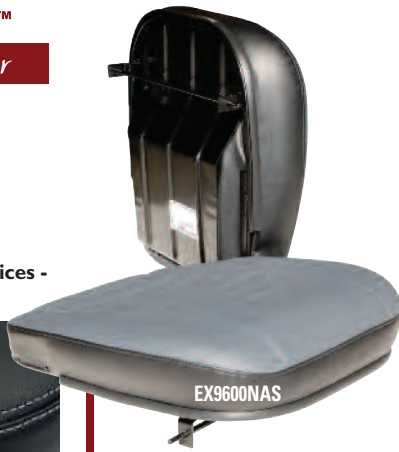

Front Seat Bottom Cushion Defender 90, 110

Twill Vinyl bottom cushion		
Driver/Pass.....	EX9975	\$ 129.00
Car Denim Vinyl bottom cushion		
Driver/Pass.....	EX9600NAS	\$ 169.00
Dark Grey Vinyl bottom cushion		
Driver/Pass.....	EX9974	\$ 139.00
Moorland bottom cushion		
Driver/Pass.....	EX9980	\$ 129.95
Black Vinyl, Driver/Pass	EX9973	\$ 119.00

Exmoor Trim Install Video

Watch Online - Search for Part Number EX11858



ExmoorTrim™

Re-trimming Defender Seat Installation Video

Defender Elite Seats with Rear Pocket

Elite Defender Seat, Front Pair with Heat & Lumbar Moorland Cloth
RNES01 \$ 1795.95

Elite Defender Seat, Front Pair with Heat & Lumbar XS Black Rack
RNES02 \$ 1995.95

Elite Defender Seat, Front Pair w/Heat & Lumbar Twill Vinyl
RNES03 \$ 1889.00



Seat Heater Kits

Sold in pairs. Includes wiring loom & Hi / Low Switches.

EX9969 \$ 199.00



Front Seat Trim Kit Defender 90, 110

Front Seat Trim Kit, Twill Vinyl	RNA5600	\$ 159.00
Front Seat Trim Kit, Dark Grey Vinyl	EX6325	\$ 161.10
Front Seat Trim Kit, Moorland Cloth	EX6331	\$ 161.10
Front Seat Trim Kit, Black Leather	EX11858	\$ 289.00
Front Seat Trim Kit, Car Denim Vinyl	EXT315NAS	\$ 178.00

Middle Seat Trim Kit

Middle Seat Trim Kit, Defender 110 NAS, 60/40 Retrim Cover Kit Moorlands ClothEX3675 \$ 399.50

More Exmoor Trim products

www.roversnorth.com/exmoor-trim



Defender Seat Risers

Increase your legroom for comfort by adding these seat risers. Quick and easy adjustment of seat height and tilt. Substantial powder coated steel frame. Fits driver or passenger side. Includes fitting instructions, bolts and Allen key. Fits existing Defender seat frame and runners (riser kit for one seat) **EXT010-5 \$ 168.90**



Tuffy Security Stereo Console

This convenient 16-gauge steel security console has 2 compartments, a separate compartment for mounting a stereo, CB Radio, or other electronic equipment, and a lockable rear storage space lined with a rubber floor mat. The spacious rear compartment accommodates a CD changer, tools, and other valuables. Requires mounting package (listed below) specifically designed for Land Rover Defender 90, RNA1702, years up to '95, does not fit 1997 Defender 90 automatic. Will fit Series Land Rover models.

- Black.....RNA1701 \$ 299.99
- Charcoal.....RNA1703 \$ 299.99
- Tuffy Mounting Kit, Series, Defender..RNA1702 \$ 14.95



RNA1701

Made in the USA for Rovers North



Defender Interior Front Door Panel RH + LH Set

This door panel set is manufactured to fit 2-piece front doors on Land Rover Series III and Defender 90 vehicles fitted with anti-burst door latches. Replicas of the original that are NLA, speaker area is not pre-cut to allow for varying sizes.

- Front Door Panel, Includes mounting hardware & instructions.....RNA4700 \$ 369.00
- Interior Door Handle, Defender 90, 110, Genuine, Also fits Series...RNF474 \$ 4.99



Discovery I & II Genuine Cup Holder Kit

*Will not fit 2003 or 2004 vehicles.

- Beige RND490 \$ 49.99
- Smokestone RND491 \$ 49.99



NEW Td5 Style



Defender Centre Dash Kit
RNA9007 \$ 269.00

Defender 90/110 Air Conditioning Kits

Update your Defender with the latest R134A Air Conditioning system as supplied on 2004 Defenders. Our exclusive Air Conditioning Kit for Defenders incorporates many improved components and features, including better ventilation and blower capacity for a faster, colder air. Includes; Lower dash fascia unit, blowers, compressor, lines, hoses, fittings, pulley, tensioner belt, evaporator, condenser and fan unit, receiver-drier, all hardware and fitting instructions.

- Defender 90/110, 300 TDI, LHD.....RNAC300 \$ 2847.25
- Defender 90/110, 3.9L V8, LHD.....RNAC39 \$ 2990.00
- Defender 90/110, 4.0L V8, LHD.....RNAC40 \$ 3150.00

Fold Away Cup Holder

Easy mount design allows for some creative placement. Perfect for Series and Defenders. Black, Made in Germany. EX7843 \$ 22.99



Floor Mats



RNA676 Discovery I



RNN213 Defender

Series II, IIA, III Insulated Rubber Floor Mats

Series II, IIA, III, Front set, Exmoor Trim	EX844	\$ 129.00
Series 88", Rear floor, Exmoor Trim	EXT0091	\$ 129.95

Defender

Defender Rubber Mat Set Front, Pre '07, Genuine	RNN213	\$ 148.50
---	--------	-----------

Exmoor Trim Insulated Rubber Floor Mats

Defender 90, Loadspace Mat, Exmoor Trim	EXT0091	\$ 129.95
Defender 4 Cylinder, Front Mat, Exmoor Trim.....	EXT0096	\$ 89.50
Defender V8, Front Mat, Exmoor Trim.....	EXT0097	\$ 79.95
Defender, Moulded Rubber Mat, Exmoor Trim	EX6136	\$ 829.00

Range Rover Classic Short Wheel Base 1987-1995

Front & Middle Rubber Floor Mat Set, Genuine	RNA624	\$ 153.47
--	--------	-----------

Range Rover 2003-2009

Front & Middle Rubber Floor Mat Set, 2003-2007, Genuine.....	RNI581	\$ 198.68
Front & Middle Rubber Floor Mat Set, 2008-2009, Genuine.....	RNI582	\$ 198.00
Loadspace Mat (not shown), Genuine	RNI583	\$ 184.00

Range Rover Sport 2006-2009

Front Rubber Floor Mat Set 2006 - '07, Genuine	RNI577	\$ 157.17
Front Rubber Floor Mat Set 2008 - '09, Genuine	RNI578	\$ 190.41
Load Space Mat, Genuine	RNI584	\$ 170.00

Discovery I 1994 - 1999

Front & Middle Rubber Floor Mat Set, Genuine.....	RNA626	\$ 179.00
Loadspace Mat w/out Rear A/C, Genuine	RNA674	\$ 149.00

Discovery II 1999-2004

Front Rubber Floor Mat Pair, Genuine	RNA708	\$ 119.00
Front & Middle Rubber Floor Mat Set, Genuine.....	RNA676	\$ 149.00
Rear Loadspace Mat, Full Length, Genuine	RNA682	\$ 268.00
Rubber Loadspace Mat, Half Length, Genuine	RNA683	\$ 129.00

LR2 2008-2009

Front Rubber Floor Mats Set, Genuine	RNI575	\$ 128.00
Rear Loadspace Mat, Genuine.....	RNI576	\$ 119.00

LR3 2005-2009

Front & Middle Rubber Floor Mat Set, Genuine.....	RNI579	\$ 159.00
Loadspace Mat, For use with 3rd Row Seats, Genuine	RNI580	\$ 69.95
Loadspace Mat, For use without 3rd Row Seats, Genuine	RNL715	\$ 219.47
Loadspace Mat, Semi ridged, ProLine	RNA319	\$ 99.84



Defender 90 Fabric Soft Top

Constructed with superior quality black fabric that will not fade, shrink or crack like the original. Year after year this top will look as good as the day you first put it on. Superior features include: weather secure door seals, heavy duty zippers & large HD Permaclear windows for improved visibility. An awesome fit on your existing belt rail system, this top ends the headaches of stretching and prying and keeps you dry and happy when the weather is foul. Includes three zip out windows, protective carrying pack and instructions. Made in the USA. **To determine your current style, search part online.**

1994 - '97 Defender 90 Soft Top, Non-Sleeved Style	RNA90ST01	\$ 2190.00
1994 - '97 Defender 90 Soft Top, Sleeved Style.....	RNA90ST02	\$ 2190.00
1994 Defender 90 Belt Rail Kit*	RNE245	\$ 82.50
1994 Defender 90 Tailgate Bar Kit*	RNE246	\$ 84.00

* The 1994 Defender 90 Soft Top is equipped from the factory with snaps and requires a belt rail and tailgate bar kit to be installed to use this top. 1995 and 1997 Defender 90 Soft top models do not require this kit.



PLD279

Defender 90 Surrey & Bimini Soft Tops

Get ready for summer with these great open air soft tops! Made with the same exacting standards as our full soft top, with or without straps.

Constructed with black OEM material.

Defender 90 Surrey Top, Made in the USA.....	PLD279	\$ 349.00
Defender 90 Bimini Top.....	RNH991	\$ 149.00



ExmoorTrim™ Authorised Distributor



EX5265

Load Curtains Fits behind front seats.

88" & 109", Defender 90, 110 with flexible window, Green	EX5264	\$ 169.95
88" & 109", Defender 90, 110 with flexible window, Sand	EX5265	\$ 169.95



Series II, IIA, III - Body Exterior

Series 109"

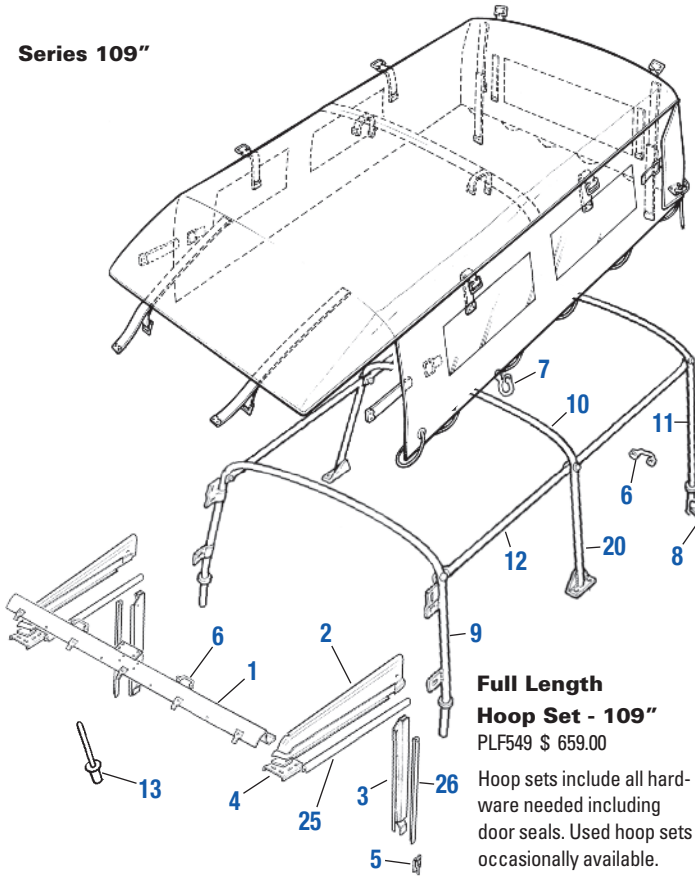

Series 88"

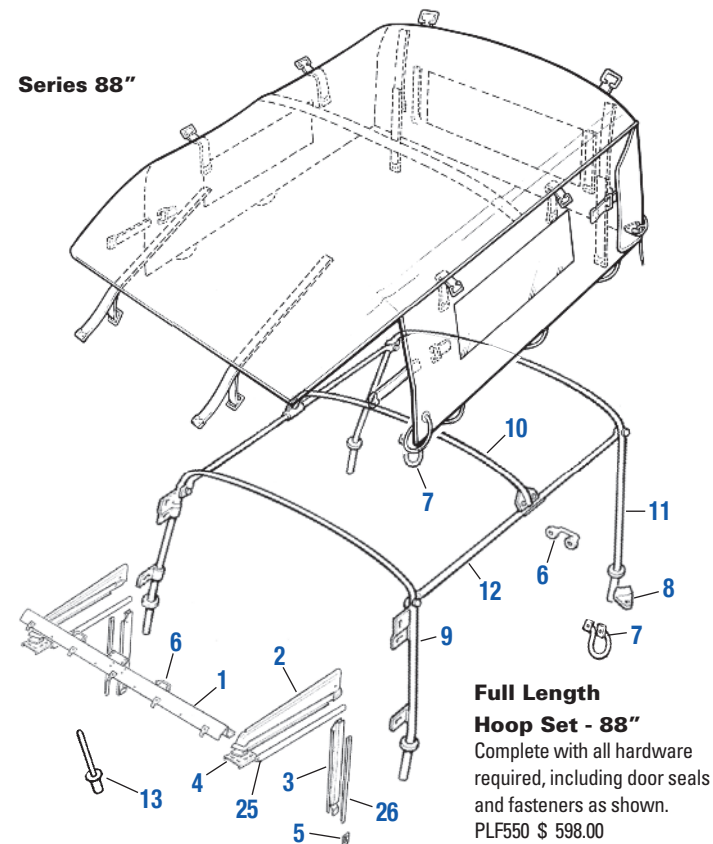

Hoop Set Components

1. Windscreen Bracket, ProLine.....	PLB736	\$ 103.43
2. Drain Channel Door Top, RH.....	PLE329	\$ 119.00
Drain Channel Door Top, LH, Genuine	RNE330	\$ 155.20
Drain Channel Door Top, RH, ProLine	PLE330	\$ 119.00
3. Drain Channel Door Post, RH.....	RNE327	\$ 36.90
Drain Channel Door Post, LH.....	RNE328	\$ 36.90
4. Corner Bracket, RH.....	RNB740	\$ 9.95
Corner Bracket, LH.....	RNB741	\$ 4.36
5. Front Tie Down, RH.....	RNB737	\$ 14.95
Front Tie Down, LH.....	RNB738	\$ 14.95
6. Tie Down Staple.....	RNE531	\$ 3.96
7. Tie Down Rear.....	RNB912	\$ 5.98
8. Hoop Bracket.....	RNB692	\$ 8.20
9. Front Hoop, 88" & 109", Genuine.....	RNB732	\$ 106.92
Front Hoop, 88" & 109", ProLine.....	PLB732	\$ 94.50
10. Middle Hoop, 88", Genuine.....	RNB734	\$ 80.25
Middle Hoop, 88", ProLine.....	PLB734	\$ 56.00
Middle Hoop, 109".....	RNB744	\$ 139.17
11. Rear Hoop, 88" & 109", Genuine.....	RNB733	\$ 148.89
Rear Hoop, 88" & 109", ProLine.....	PLB733	\$ 86.60
12. Tie Tube, 88".....	RNB735	\$ 57.57
Tie Tube, 109".....	RNB745	\$ 63.47
13. Pop Rivet for Hoop Set.....	RNC690	\$ 0.95
14. Cab Surround for securing 3/4 truck canvas to truck cab.....	RNB766	\$ 137.84
15. Bottom Drain Channel, RH.....	RNB793	\$ POA
Bottom Drain Channel, LH.....	EXT2217	\$ 59.80
17. Canvas Clamp, RH.....	RNB848	\$ 4.51
Canvas Clamp, LH.....	RNB849	\$ 5.87
18. Three piece batten for securing kit canvas to cab surround.....	PLF551	\$ 57.95
19. Horizontal batten.....	RNB795	\$ POA
20. Middle Hoop, 109".....	RNB744	\$ 139.17
21. Tie Tube Rear, 109".....	RNB745	\$ 63.47
22. Tie Tube Front, 109".....	RNB746	\$ 45.69
23. Tie Tube, 88" 3/4.....	PLB818	\$ 39.95
24. Front Hoop, 88" 3/4.....	PLB819	\$ 79.95
25. Door Seal Top.....	RNC120	\$ 17.95
26. Door Seal Top Back.....	RNC121	\$ 17.95

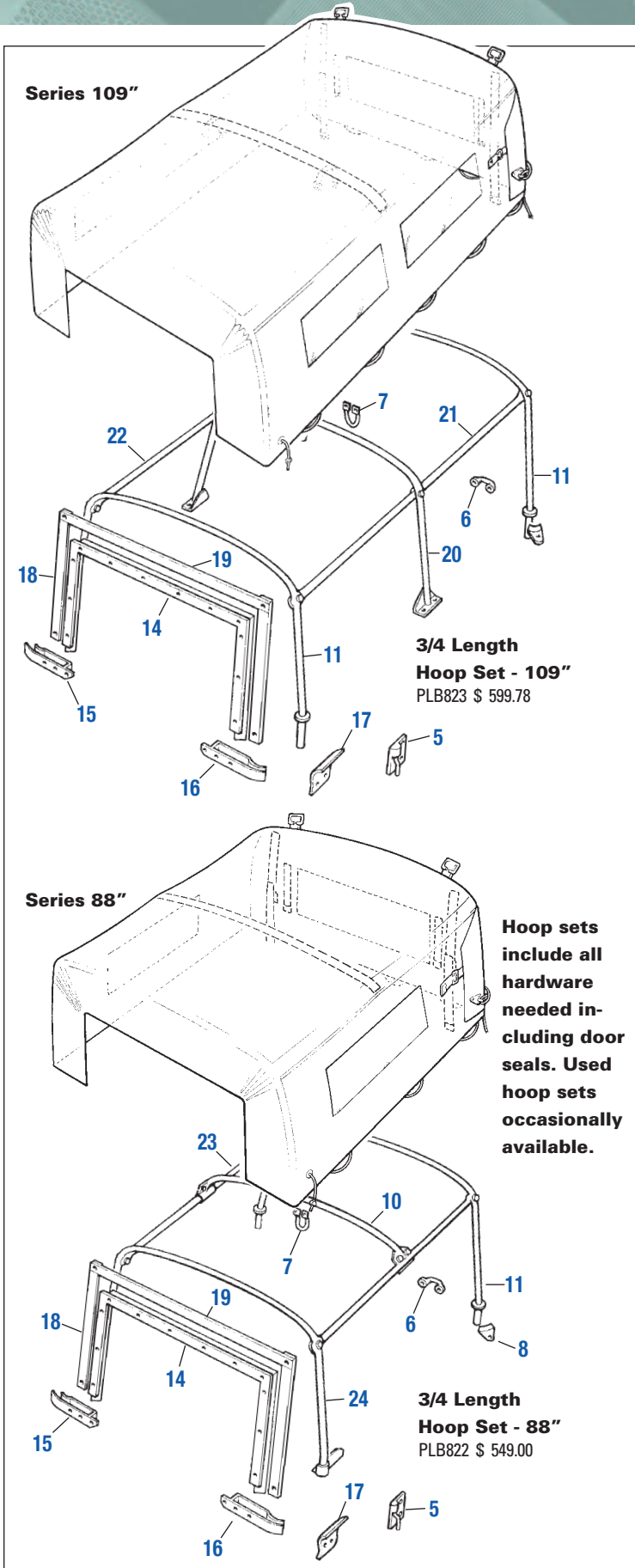

PLB769 Series 109" 3/4 Length, Plain Canvas w/o windows, Khaki (Green)

ExmoorTrim™
Authorised Distributor



Deep Weave Classic Canvas Tops exclusively from Exmoor Trim have brought the traditional canvas for Land Rovers into the 21st century but have managed to retain all of its classic 60 year authentic look & feel.

Exmoor Trim delved deep into the original canvas archives, to get the canvas back to the original colors as they have been diluted over many years.

With the benefit of modern methods Exmoor Trim has increased the lifespan of this Deep Weave Classic Canvas by reducing all the natural pitfalls of a 100% natural cotton canvas.

Canvas Tops - 88" & 109"

88" Full Length

Deep Weave Classic, plain w/o side windows, Khaki (Green).....	PLB750	\$ 495.95
Deep Weave Classic, plain w/o side windows, Sand.....	PLB748	\$ 460.95
Deep Weave Classic, w/side windows, Khaki (Green).....	PLB754	\$ 499.00
Deep Weave Classic, w/side windows, Sand.....	PLB752	\$ 549.00
Deep Weave Classic, w/side windows, Black.....	PLB753	\$ 579.00

109" Full Length

Deep Weave Classic, plain w/o side windows, Khaki (Green).....	PLB758	\$ 471.45
Deep Weave Classic, plain w/o side windows, Sand.....	PLB756	\$ 503.95
Deep Weave Classic, w/side windows, Khaki (Green).....	PLB763	\$ 619.00
Deep Weave Classic, w/side windows, Sand.....	PLB761	\$ 699.00

88" 3/4 Length

Deep Weave Classic, plain w/o side windows, Khaki (Green).....	PLB778	\$ 388.45
Deep Weave Classic, plain w/o side windows, Sand.....	PLB775	\$ 398.95
Deep Weave Classic, w/side windows, Khaki (Green).....	PLB781	\$ 419.95
Deep Weave Classic w/side windows, Black.....	EX3754	\$ 399.89

109" 3/4 Length

Deep Weave Classic, plain w/o side windows, Khaki (Green).....	PLB769	\$ 489.00
Deep Weave Classic, plain w/o side windows, Sand.....	PLB767	\$ 499.00
Deep Weave Classic, w/side windows, Sand.....	PLB771	\$ 599.00

Preserving the fit of your canvas top

Your new canvas top will shrink if you allow it to get wet while the sides and or back are rolled up. To help prevent shrinkage when canvas top is new, keep sides and back fully secured down and allow it to get wet and let dry several times. This lets the canvas conform to the vehicle and hoop set.

Annual applications of canvas top preservative greatly prolongs the canvas life.

Canvas Preservative Keeps your canvas top waterproof.

(One gallon covers one 109" full length top.) 1-gallon container.....**CANVAK \$ 35.95**



Rigid Tire Covers Easier to Clean!

Standard fits tire sizes 205/80x16", 235/70x16", 255/75x16" and 255/55x18"

Large fits tire sizes 245/75x16", 7.50x16", 235/85x16" and 265/75x16"

(A) Land Rover Logo Rigid Tire Cover

Standard.....	RNA3804	\$ 119.00
Large.....	RNA3811	\$ 129.00

(B) Land Rover Rigid Safari Tire Cover

Standard.....	RNA3885	\$ 119.00
Large.....	RNA3869	\$ 129.00

(C) Land Rover Rigid Rhino Tire Cover

Standard.....	RNA3857	\$ 119.00
Large.....	RNA3892	\$ 129.00

(D) Land Rover Rigid Lion Tire Cover

Standard.....	RNA3820	\$ 119.00
Large.....	RNA3834	\$ 129.00



Soft Tire Covers

Standard fits tire sizes 205/80x16", 235/70x16", 255/75x16" and 255/55x18"

Large fits tire sizes 245/75x16", 7.50x16", 235/85x16" and 265/75x16"

(E) Land Rover Logo Tire Cover

Standard.....	RNE387	\$ 65.50
Large.....	RNE386	\$ 65.50

(F) Land Rover on Safari Tire Cover

Standard.....	RNTCSAL	\$ 69.50
Large.....	RNTCSBL	\$ 69.50

(G) Land Rover Rhino Tire Cover

Standard.....	RNTCRAL	\$ 69.50
Large.....	RNTCRBL	\$ 69.50

(H) Land Rover Elephant Tire Cover

Standard.....	RNTCEAL	\$ 69.50
Large.....	RNTCEBL	\$ 69.50





Series II, IIA, III

6" x 10" Mirror Head

RNF260 \$13.99



5" x 7" Mirror Head

RNF259 \$12.50



8 1/2" Mirror Arm

Mounts to wing top & Series IIA hinges with mirror mount.

Fits RNF259 & RNF260

ARM2 \$14.50

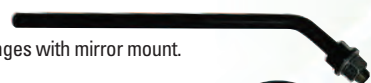

Round Mirror Head

PLC633 \$12.95 ea



Interior Mirror

Series II, IIA, III

PLB905 \$14.90



Defender Convex Mirror Assemblies

Defender Convex Mirror Assembly

Standard size 5" x 8", head with 6 1/2" arm, shown at right. RNE314 \$36.00 ea

All of these can be mounted on Series with Defender door hinge kits.



Mirror Kits, 5" x 8"

Mirror Kit, LH RNK841L \$ 80.33

Mirror Kit, RH RNK841R \$ 80.33

X Large 10" x 6"

Head with 6 1/2" arm

RNH716 \$42.50 ea



Mirror Kits, 10" x 6"

Mirror Kit, LH RNK851L \$ 87.50

Mirror Kit, RH RNK851R \$ 87.50

XX Large 10" x 6" Head

with 11" arm.

RNI127 \$59.00 ea



Genuine Door Hinge Kits

Defender 90, Series II-III 88" RNK8060 \$ 289.00

Defender 110, Series II-III 109" RNK8061 \$ 549.00 ea



Clutch, Master Cylinder

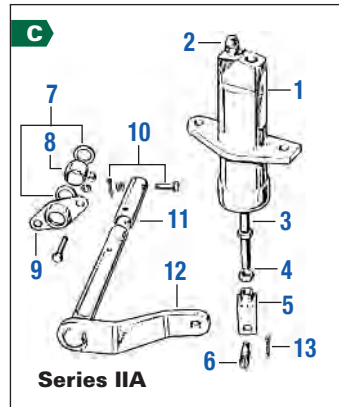
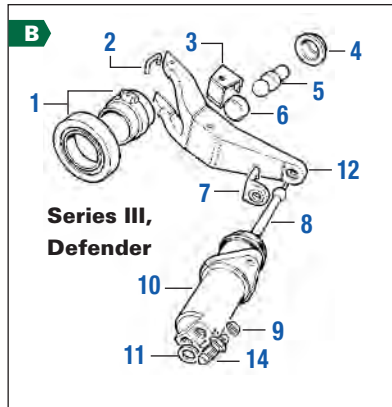
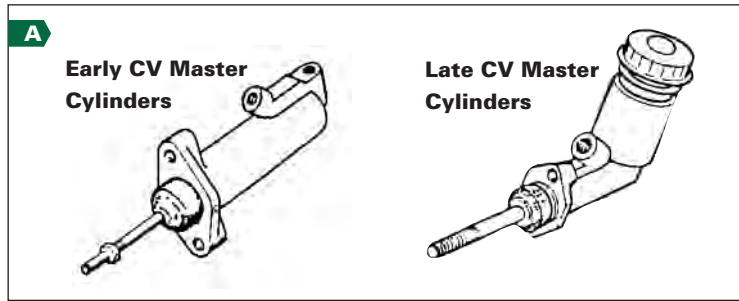

A Clutch Master Cylinders

Series II, IIA 1959 - 1968 early CV type, ProLine	PLC752	\$ 64.50
Series IIA, III, Defender all models, 1969 - 2007 late CV type		
with fluid reservoir, Genuine.....	RNF289	\$ 102.08
ProLine.....	PLF289	\$ 69.50
Rebuild kit for all CV Master Cylinders 1959 - 2007, Genuine	RNC720	\$ 17.54
Cap with seal for Late CV Master Cylinder, Genuine	RNF290	\$ 22.96
Cap with seal for Late CV Master Cylinder, ProLine.....	PLF290	\$ 6.80

B Clutch Withdrawal Mechanism

Series III, Defender

1. Throw-Out Bearing, Genuine	RNE223	\$ 57.95
2. Plastic Staple, Genuine	RNC483	\$ 0.60
3. Retainer for Operating Arm, Genuine	RNC465	\$ 2.18
4. Retainer Collar, Genuine	RNC466	\$ 3.28
5. Fulcrum, 3.9 Litre, Genuine	RNE172	\$ 11.26
6. Bush for operating arm, Genuine	RNC464	\$ 1.47
7. Retainer for Push Rod, Genuine	RNC493	\$ 3.95
8. Push Rod for Slave Cylinder, 2.25 Litre, Genuine	RNC463	\$ 29.06
Push Rod for Slave Cylinder, 2.25 Litre, ProLine.....	PLC498	\$ 6.25
Push Rod for Slave Cylinder, Defender w/LT77, All 4 cyl, Genuine...	RNI700	\$ 9.15
Push Rod for Slave Cylinder, Defender w/R380, All 4 cyl, Genuine...	RNI701	\$ 38.15
9. Dust Cap for Bleeder, Genuine	RNF316	\$ 2.59
10. Slave Cylinder, 2.25, 2.5 Litre & 200 TDI w/LT77 Gearbox, Genuine	RNC535	\$ 98.20
Slave Cylinder, 2.25 & 2.5 Litre, ProLine.....	PLC535	\$ 39.50
Slave Cylinder, 3.9 Litre V8, Genuine.....	RNE222	\$ 64.90
Slave Cylinder, 3.9 Litre V8, ProLine.....	PLE222	\$ 36.80
Slave Cylinder, 300 Tdi, up to #56A0669086K, Genuine.....	RND627	\$ 79.90
Slave Cylinder, 300 Tdi & Td5 up to #56A0669087K, Genuine.....	RND493	\$ 69.80
Slave Cylinder, 300 Tdi & Td5 up to #56A0669087K, ProLine.....	PLD493	\$ 58.50
11. Compression Washer, Genuine	RNA986	\$ 0.48
12. Release Lever, Series III, Defender V8 & Td5, Genuine	RNC481	\$ 79.50
Release Lever, Defender 2.5, 200 & 300 Tdi, Genuine.....	RNH396	\$ 33.95

C Clutch Slave Cylinder & Linkage

Series II & IIA (Located at Bell Housing area)

1. Slave Cylinder, Genuine	RNB599	\$ 119.95
Slave Cylinder, ProLine.....	PLB599	\$ 48.50
2. Bleed Screw, Genuine	RNC380	\$ 3.25
3. Push Rod, Genuine	RNC293	\$ 17.34

4. Lock Nut, Genuine	RNS034	\$ 1.59
5. Clevis for Push Rod, Genuine	RNB638	\$ 4.60
6. Threaded Clevis Pin, Genuine	RNA932	\$ 23.60
7. Felt Ring for Spherical Bushing, Genuine	RNA946	\$ 0.80
8. Spherical Bush, Genuine	RNC733	\$ 24.99
9. Housing for Spherical Bush, Genuine	RNB380	\$ 10.87
10. Pin for Cross Shaft (two required), Genuine	RNC290	\$ 3.96
11. Connecting Tube, Genuine	RNC403	\$ 59.95
12. Operating Lever, 2.25 Litre, Genuine	RNC294	\$ 29.25
13. Split pin for clevis, Genuine	RNB315	\$ 0.29

Rubber Boot for Cross Shaft

Seals, Cross Shaft to Bell Housing, Genuine (not shown)	RNC371	\$ 15.95
--	--------	----------

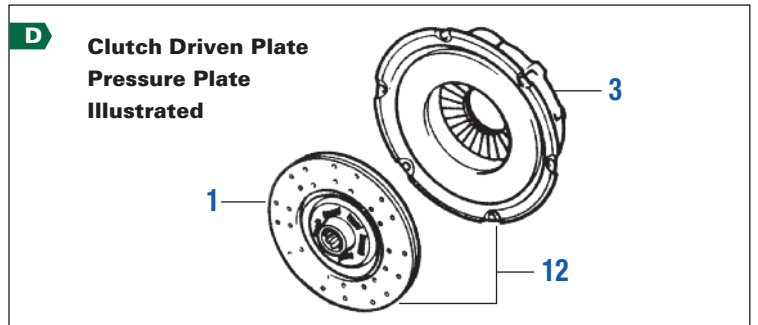

D Clutch Driven Plate - NEW

1. Series II, IIA thru 1966, 9", ProLine	PLC546	\$ 89.94
Series II, IIA, 9.5", Genuine.....	RNE170	\$ 98.76
Series II, IIA, 9.5", ProLine.....	PLE170	\$ 79.88
Defender V8, 10", Genuine	RNE220	\$ 229.95
Defender V8, 10", ProLine.....	PLE220	\$ 84.20
Defender 2.5, 200 & 300 Tdi, 10", Genuine.....	RNI702	\$ 158.72
Defender TD5, 10", Genuine.....	RNI703	\$ 192.00

Clutch Pressure Plate - NEW

2. Series II, IIA thru 1966, 9", ProLine	PLC547	\$ 139.00
Series II, IIA, 9.5", ProLine.....	PLC467	\$ 139.80
Series III, 2.25, 2.6 Litre, 9.5", Genuine.....	RNC486	\$ 139.00
Series III, Defender V8, 10", ProLine.....	RNC485	\$ 269.00
Defender 2.5, 200 & 300 Tdi, 10", Genuine	RNH534	\$ 113.95
Defender TD5, 10", Genuine.....	RNI704	\$ 215.00

Complete Clutch Kit

Includes driven plate, pressure plate and throwout bearing.

3. Series III, ProLine	PLB372	\$ 189.95
Defender V8, Genuine	RNH608	\$ 371.18
Defender V8, ProLine.....	PLH608	\$ 268.20
Defender 2.5 NA, 200 & 300 Tdi, Genuine.....	RNI705	\$ 269.00



**Series III & Defender
PLE223**

Throwout Bearing Assembly

Series III & Defender all models, Genuine	RNE223	\$ 57.95
Series III & Defender all models, ProLine	PLE223	\$ 19.95

Clutch Alignment Tool

Series II, IIA, III, 2.25 & 2.6 Litre	TLS33	\$ 5.45
Defender V8	TLS33D	\$ 5.45



Which Defender gear box do I have?

LT77, LT77S - Reverse is forward to the left.

R380 - Reverse is rearward to the right.

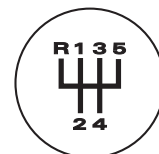

LT77 / LT77S

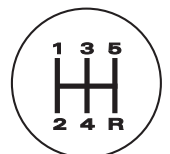

R380

Drum Brakes, Master & Wheel Cylinders

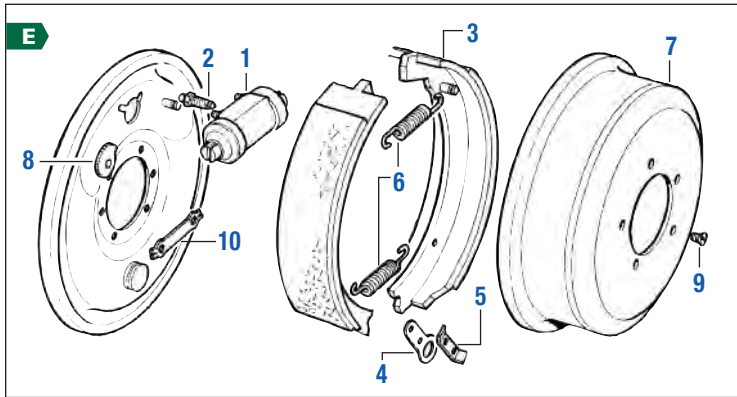

E Wheel Cylinders, Shoes, Drums

	Genuine	ProLine
1. 88", Series II, IIA, III Front Right	RNB535 \$ 79.98	PLB535 \$ 36.85
88", Series II, IIA, III Front Left	RNB536 \$ 79.98	PLB536 \$ 36.85
88", Series II, IIA, III Rear Right	RNB537 \$ 78.00	PLB537 \$ 39.50
88", Series II, IIA, III Rear Left	RNB538 \$ 78.00	PLB538 \$ 39.50
109", 2.25 Litre Front Right	RNB542 \$ POA	PLB542 \$ 36.90
109", 2.25 Litre Front Left	RNB541 \$ POA	PLB541 \$ 36.90
109", 2.25 Litre Rear Right	RNB535 \$ 79.98	PLB535 \$ 36.85
109", 2.25 Litre Rear Left	RNB536 \$ 79.98	PLB536 \$ 36.85
109", 2.6, 3.5 Litre Front Right	RNC600 \$ 257.75	PLC600 \$ 38.90
109", 2.6, 3.5 Litre Front Left	RNC599 \$ 257.75	PLC599 \$ 38.90
109", 2.6, 3.5 Litre Rear Right	RNB535 \$ 79.98	PLB535 \$ 36.85
109", 2.6, 3.5 Litre Rear Left	RNB536 \$ 79.98	PLB536 \$ 36.85
Defender 90 thru Oct '93 Rear Right	RNF349 \$ 219.00	PLF349 \$ 82.43
Defender 90 thru Oct '93 Rear Left	RNF348 \$ 219.00	PLF348 \$ 82.43
Defender 110 thru Oct '93 Rear Right	RNE635 \$ 118.90	
Defender 110 thru Oct '93 Rear Left	RNE636 \$ 118.90	

2. Bleed Screws for Wheel Cylinders, Genuine	RNC380	\$ 3.25
Dust Cap for bleed screws, Genuine	RNF316	\$ 2.59

Bonded Brake Shoes sold in axle sets Enough for 2 wheels

3. 88", 90" bonded shoe axle set, front or rear, Mintex	PLF320M	\$ 49.95
88", 90" bonded shoe axle set, front or rear, ProLine	PLF320	\$ 34.50
109" 2.25 Litre bonded shoe axle set, front only, Mintex	PLF343M	\$ 59.20
109" 2.25 Litre bonded shoe axle set, front only, ProLine	PLF343	\$ 39.99
2.6, 3.5 Litre bonded shoe axle set, front only, ProLine	PLF344	\$ 69.25
109", 110" bonded shoe axle set, rear only, all models, Mintex	PLF321M	\$ 68.45
109", 110" bonded shoe axle set, rear only, all models, ProLine	PLF321	\$ 34.50
Series IIA, III 2.5 Litre brake shoes for handbrake, ProLine	PLF342	\$ 19.95
4. 88", 90" retainer for brake shoes, Genuine	RND064	\$ 15.86
5. 88", 90" locker for retainer, Genuine	RND065	\$ 2.18

Shoe Return Springs

6. 88" front & rear, all models thru June '80		
Top, Genuine	RNC165	\$ 4.28
Bottom, Genuine	RNA952	\$ 4.98
109", 110" all models with drum brakes		
Front, Genuine	RNA993	\$ 7.20
Rear top, Genuine	RNC345	\$ 18.94
Rear bottom, Genuine	RNC273	\$ 5.59
90" all models with rear drum brakes		
Top, Genuine	RNC165	\$ 4.28
Bottom, Genuine	RNA952	\$ 4.98

Brake Drums

7. 88" Series II, IIA, 10", ProLine	PLC545	\$ 42.50
88" Series III, 90" rear, 10", ProLine	PLC534	\$ 39.50
109" Series IIA, III 2.25 Litre 1971 on, 110" rear, ProLine	PLC504	\$ 39.50
8. Adjuster Kit		
Easy bolt together, does 4 adjusters (109" requires 2 kits), ProLine	PLE588	\$ 29.99
9. Drum Screw Fits all Series, ProLine	PLA915	\$ 0.50

F CV Master Cylinder

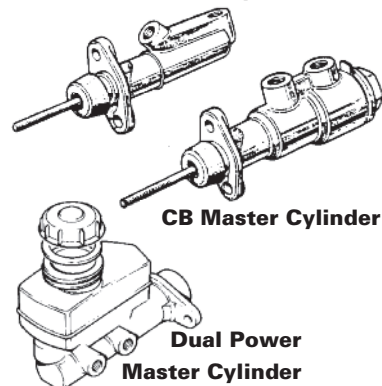

**Series II, IIA
Reproduction
Reservoir
PLI107A \$ 129.95**

F Brake Master Cylinders

Series II, IIA 88" CB, 1959 - 1967, ProLine	PLC228	\$ 64.50
Series IIA 88" CV, 1967 - 1968, ProLine	PLC752	\$ 64.50
Series II, IIA 109", 1959 - 1967, CB, ProLine	PLC429	\$ 69.48
Series IIA 109", 1968 - 1969, CV, ProLine	PLC753	\$ 49.95
Series Single System Power, except V8	PLH407	\$ 49.95
Series IIA, III 88" Dual Power, Genuine	RNC454	\$ 299.80
Series IIA, III 88" Dual Power, ProLine	PLC454	\$ 138.00
Series IIA, III, 109" Dual Power, Genuine	RNC762	\$ 299.00
Series IIA, III, 109" Dual Power, ProLine	PLC762	\$ 129.00
Series II, IIA Reservoir, Reproduction	PLI107A	\$ 129.95

Rebuild Kit, Series IIA, III 88"

Dual Power Master Cylinder	PLC770	\$ 48.90
----------------------------	--------	----------

Complete Series Vehicle Brake Pipe Kits

Includes all Genuine metal and rubber flex lines with sealing washers and nuts.

88" early Series IIA, single system kit	RNK680	\$ 167.95
109" single system kit	RNK681	\$ 169.95
88" Series IIA, dual power system kit	RNK682	\$ 199.50
88" Series III, dual power system kit	RNK683	\$ 199.50



G Stainless Steel Brake Line Kits

These 4 inch extended flexible stainless steel brake line kits are designed for Land Rovers with lifted suspension. Replaces your rubber flex lines. Equipped with factory fittings. No adapters required. Directions included.

Extended Length

Defender	SBL2003E	\$ 89.50
Discovery I	SBL3004E	\$ 129.00
Discovery II	SBL6004E	\$ 119.00
Range Rover Classic 1986-1989	SBL5005E	\$ 165.00
Range Rover Classic 1990-1991	SBL5007E	\$ 179.99
Range Rover Classic 1992-1995	SBL5006E	\$ 179.99

Standard Length

Series II, IIA, 88"	RNA1076	\$ 79.50
Series III, 88"	RNA1032	\$ 78.50
Series II, IIA, 109"	RNA1091	\$ 79.50
Series III, 109"	RNA1033	\$ 78.50

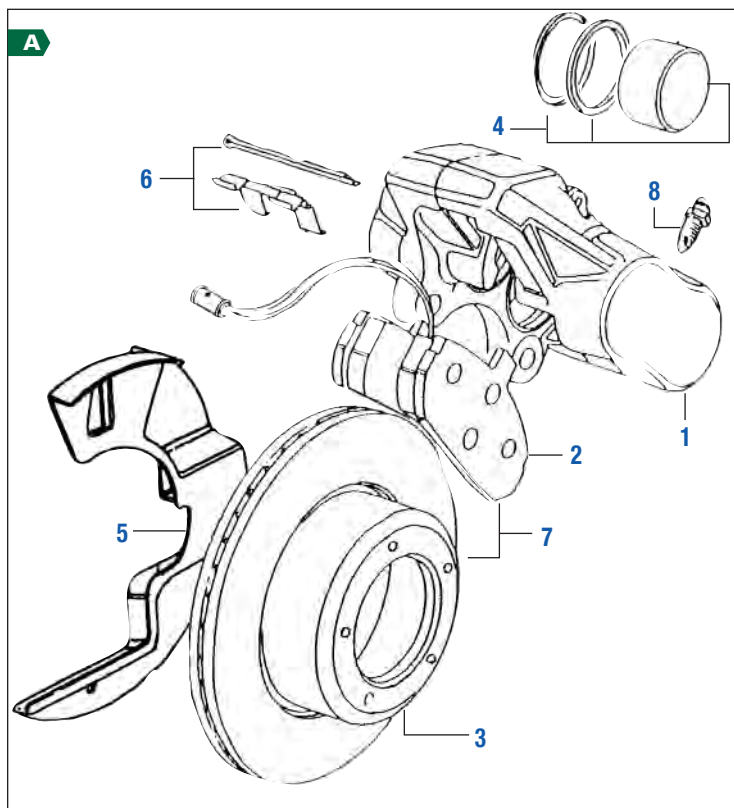

Genuine & ProLine Brake Pads

2. Defender 90 1994-2010

Front, Brake Pad set, Genuine.....	RNF302	\$ 89.90
Front, Brake Pad set, ProLine.....	PLF323	\$ 36.50
Rear, Brake Pad set, Genuine.....	RNF303	\$ 61.99
Rear, Brake Pad set, ProLine.....	PLB195	\$ 24.95

Defender 110

Front, Brake Pad set, 1984-2010, Genuine.....	RNF302	\$ 89.90
Front, Brake Pad set, 1984-2010, ProLine.....	PLF323	\$ 36.50
Rear, Brake Pad set, 1994-2006, Genuine.....	RNH601	\$ 75.02
Rear, Brake Pad set, 1994-2006, ProLine.....	PLH601	\$ 39.95
Rear, Brake Pad set, 2007-2010, Genuine.....	RNI162	\$ 89.60

Discovery I 1995-1999

Front, Brake Pad, set, ProLine.....	PLB208	\$ 36.50
Rear, Brake Pad set, ProLine.....	PLB195	\$ 24.95

Discovery II 1999-2004

Front, Brake Pad set, Genuine.....	RND036	\$ 68.90
Front, Brake Pad set, ProLine.....	PLD036	\$ 42.95
Rear, Brake Pad set, Genuine.....	RND020	\$ 96.80
Rear, Brake Pad set, ProLine.....	PLD242	\$ 39.50

Range Rover Classic 1987-1995

Front, Brake Pad set, '87-1989, Genuine.....	RNB001	\$ 69.99
Front, Brake Pad set, '87-1989, non ABS, ProLine.....	PLB001	\$ 35.95
Front, Brake Pad set, '90-1995, Genuine.....	RNB002	\$ 59.00
Front, Brake Pad set, '90-1995, ProLine.....	PLB208	\$ 36.50
Rear, Brake Pad set, '87-1995, Genuine.....	RNB004	\$ 89.95
Rear, Brake Pad set, '87-1995, ProLine.....	PLB004	\$ 49.99

Range Rover P38A 1995-2002

Front, Brake Pad set, ProLine.....	PLD036	\$ 42.95
Rear, Brake Pad, set ProLine.....	PLD242	\$ 39.50

Range Rover L322 (2003 on)

Front, Brake Pad set up to 4A159171, Genuine.....	RNH715	\$ 119.33
Front, Brake Pad set up to 4A15917, ProLine.....	PLH715	\$ 61.95
Rear, Brake Pad set up to 6A000001, Genuine.....	RNH594	\$ 149.99

LR3 (2004 on)

Brake Pad set, front, Genuine.....	RNH721	\$ 99.51
Brake Pad set, front, ProLine.....	PLH721	\$ 69.95
Brake Pad set, rear, Genuine.....	RNH958	\$ 96.95
Brake Pad set, rear, ProLine.....	PLH958	\$ 54.50

Genuine & ProLine Brake Rotors

3. Defender 90, 110

Front solid rotor, each, Genuine.....	RNB006	\$ 89.95
Front solid rotor, each, ProLine.....	PLB006A	\$ 39.50
Front vented rotor, each, Genuine.....	RNB022	\$ 86.50
Front vented rotor, each, ProLine.....	PLB022A	\$ 39.50
Rear rotor, each, 110 only 1994-2007, Genuine.....	RNI721	\$ 115.16
Rear rotor, each, 110 only 1994-2007, ProLine.....	PLB012A	\$ 39.00
Rear rotor, each, 90 only, non ABS, 2007-2010, Genuine.....	RNI154	\$ 89.60
Rear rotor, each, 90 only with ABS, 2007-2010, Genuine.....	RNI721	\$ 115.16

Discovery I 1995-1999

Front, rotor, each, Genuine.....	RNB006	\$ 89.95
Front, rotor, each, ProLine.....	PLB006A	\$ 39.50
Rear, rotor, each, Genuine.....	RNI721	\$ 115.16
Rear, rotor, each, ProLine.....	PLB012A	\$ 39.00

Discovery II 1999-2004

Front, rotor, each, Genuine.....	RND013	\$ 99.50
Front, rotor, each, ProLine.....	PLD013A	\$ 45.00
Rear, rotor, each, Genuine.....	RND024	\$ 94.00
Rear, rotor, each, ProLine.....	PLD024A	\$ 39.95

Range Rover Classic 1987-1995

Front rotor '87-1989, each, Genuine.....	RNB006	\$ 89.95
Front rotor '87-1989, each, ProLine.....	PLB006A	\$ 39.50
Front rotor '90-1995, each, Genuine.....	RNB022	\$ 86.50
Front rotor '90-1995, each, ProLine.....	PLB022A	\$ 39.50
Rear rotor '87-1995, each, Genuine.....	RNI721	\$ 115.16
Rear rotor '87-1995, each, ProLine.....	PLB012A	\$ 39.00

A NEW ProLine Brake Calipers (no Core Charge)

1. Defender 90/110 1993-1997

Defender 90, Front Caliper, NEW, RH.....	PLF300A	\$ 138.00
Defender 90, Front Caliper, NEW, LH.....	PLF301A	\$ 138.00
Defender 90, Rear Caliper, NEW, RH.....	PLB198A	\$ 99.80
Defender 90, Rear Caliper, NEW, LH.....	PLB197A	\$ 99.80
Defender 110, Front Caliper, NEW, RH.....	PLF200	\$ 127.60
Defender 110, Front Caliper, NEW, LH.....	PLF201	\$ 127.60

Discovery I 1995-1999

Front Caliper, NEW, RH.....	PLB192A	\$ 149.00
Front Caliper, NEW, LH.....	PLB191A	\$ 149.00
Rear Caliper, NEW, RH.....	PLB198A	\$ 99.80
Rear Caliper, NEW, LH.....	PLB197A	\$ 99.80

Discovery II 1999-2004 & Range Rover P38A 1995-2002

Front Caliper, NEW, RH.....	PLD016A	\$ 119.00
Front Caliper, NEW, LH.....	PLD017A	\$ 119.00
Rear Caliper, NEW, RH.....	PLD004	\$ 98.00
Rear Caliper, NEW, LH.....	PLD005	\$ 98.00

Range Rover Classic 1987-1995

Front Caliper, NEW, 1987-1989 RH.....	PLB014A	\$ 159.00
Front Caliper, NEW, 1987-1989 LH.....	PLB015A	\$ 159.00
Front Caliper, NEW, 1993-1995 RH, From Vin # 637568.....	PLD259A	\$ 159.00
Front Caliper, NEW, 1993-1995 LH, From Vin # 637568.....	PLD258A	\$ 179.00
Front Caliper, NEW, ABS & Hunter, '90-1995, RH.....	PLB011A	\$ 149.00
Front Caliper, NEW, ABS & Hunter, '90-1995, LH.....	PLB017A	\$ 149.00
Rear Caliper, NEW, 1987-1992 RH 10mm.....	PLB018A	\$ 139.50
Rear Caliper, NEW, 1987-1992 LH 10mm.....	PLB010A	\$ 139.80
Rear Caliper, NEW, 1993-1995 RH 12mm.....	PLB198A	\$ 99.80
Rear Caliper, NEW, 1993-1995 LH 12mm.....	PLB197A	\$ 99.80



Brake & Clutch Fluid

Brake Fluid, Land Rover, Suitable for all

Land Rover Vehicles. 12oz.....	LRNDOT4	\$ 7.99
Brake Fluid, Girling, TRW, 1 litre (33oz).....	GBF4100	\$ 11.99
Brake Fluid, Girling, TRW, 500ml (16.9oz).....	GBF4500	\$ 5.99

Genuine & ProLine Brake Rotors (con't)

3. Range Rover P38A 1995-2002			
Front rotor, each, Genuine	RND028	\$	99.40
Front rotor, each, ProLine	PLD028A	\$	44.50
Rear rotor, each, Genuine	RND024	\$	94.00
Rear rotor, each, ProLine	PLD024A	\$	39.95
Range Rover L322 2003 on			
Front rotor, up to 3A130140, each, Genuine	RNH909	\$	179.00
Front rotor, up to 3A130140, each, ProLine	PLH909	\$	68.00
Front rotor, from 4A159171 up to 6A228066, each, Genuine	RNH954	\$	112.80
Rear rotor, up to 6A000001, each, Genuine	RNH955	\$	119.00
Rear rotor, up to 6A000001, each, ProLine	PLH955	\$	58.00
LR3 2004 on			
Front rotor, each, Genuine	RNH956	\$	99.50
Front rotor, each, ProLine	PLH956	\$	59.95
Rear rotor, each, Genuine	RNI350	\$	97.50
Rear rotor, each, ProLine	PLI350	\$	48.50

Caliper Rebuild Kits Includes pistons and seals for one caliper.

4. Defender 90 front caliper kit per side, ProLine			
	PLF304	\$	29.80
Defender 90 Rear caliper kit per side, Genuine	RNB246	\$	96.65
Defender 90 rear caliper kit per side, ProLine	PLB246	\$	29.95
Defender 110 front caliper kit per side, ProLine	PLF318	\$	9.95
Range Rover Classic 1987-1999			
Front caliper kit per side, ProLine	PLB024	\$	7.95
Rear caliper kit per side, ProLine	PLB009	\$	7.95
Discovery I 1994-1999			
Front caliper kit per side, ProLine	PLB176	\$	36.50
Rear caliper kit per side, ProLine	PLB246	\$	29.95

5. Mud Shield

Defender 90 front RH, Genuine	RNB178	\$	29.50
Defender 90 front LH, Genuine	RNB177	\$	29.50
Defender 90 rear RH, Genuine	RNB206	\$	26.50
Defender 90 rear LH, Genuine	RNB205	\$	26.50
Defender 110 front RH, Genuine	RNE195	\$	78.64
Defender 110 front LH, Genuine	RNE196	\$	78.64
Defender 110 rear RH, Genuine	RNB206	\$	26.50
Defender 110 rear LH, Genuine	RNB205	\$	26.50

Discovery I 1994-1999, Range Rover Classic 1987-1995

Discovery I Front RH, Genuine	RNB178	\$	29.50
Discovery I Front LH, Genuine	RNB177	\$	29.50
Discovery I Rear RH, Genuine	RNI183	\$	119.91
Discovery I Rear LH, Genuine	RNI182	\$	119.95

Discovery II 1999-2004, Range Rover P38A 1996-2002

Discovery II Front RH, Genuine	RND964	\$	29.86
Discovery II Front LH, Genuine	RND965	\$	29.86
Discovery II Rear RH & LH, Genuine	RNE004	\$	29.15

6. Fixing Kits for Brake Pads

Defender 110 NAS, Discovery I, front, solid disc, ProLine	PLB204	\$	3.99
Range Rover Classic, Defender 90 NAS, front, vented, ProLine	PLD161	\$	6.95
Range Rover Classic, front, non-vented, ProLine	PLH320	\$	5.50
Range Rover Classic, Defender 90, Discovery I, rear, solid disc, ProLine	PLH321	\$	4.50

7. Brake Kits Genuine & ProLine kits include 2 pads, 2 rotors & hardware.

Range Rover Classic 1987-1995			
Front Brakes non ABS, Genuine	RNK6101	\$	209.00
Front Brakes non ABS, ProLine	PLK6101	\$	109.00
Rear Brakes non ABS LH Sensor, Genuine	RNK6102	\$	289.00
Rear Brakes non ABS LH Sensor, ProLine	PLK6102	\$	129.00
Rear Brakes non ABS RH Sensor, Genuine	RNK6103	\$	269.00
Rear Brakes non ABS RH Sensor, ProLine	PLK6102	\$	129.00
Front Brakes w/ABS, Genuine	RNK6104	\$	236.00
Front Brakes w/ABS, ProLine	PLK6104	\$	118.90
Rear Brakes w/ABS, Genuine	RNK6105	\$	269.00
Rear Brakes w/ABS, ProLine	PLK6105	\$	129.00

7. Range Rover P38A 1995-2002

Front Brakes, Genuine	RNK6112	\$	329.00
Front Brakes, ProLine	PLK6112	\$	124.00
Rear Brakes, Genuine	RNK6113	\$	276.00
Rear Brakes, ProLine	PLK6113	\$	99.50

Discovery I 1995-1999

Front Brakes, Genuine	RNK6106	\$	239.99
Front Brakes, ProLine	PLK6106	\$	110.00
Rear Brakes, Genuine	RNK6107	\$	245.00
Rear Brakes, ProLine	PLK6107	\$	94.50

Discovery II 1999-2004

Front Brakes, Genuine	RNK6114	\$	264.99
Front Brakes, ProLine	PLK6114	\$	129.90
Rear Brakes, Genuine	RNK6115	\$	279.50
Rear Brakes, ProLine	PLK6115	\$	99.99

Defender 90

Front Brakes, Genuine	RNK6110	\$	249.00
Front Brakes, ProLine	PLK6110	\$	112.99
Rear Brakes, Genuine	RNK6111	\$	239.95
Rear Brakes, ProLine	PLK6111	\$	89.00

Defender 110

Front Brakes, Genuine	RNK6108	\$	219.00
Front Brakes, Genuine	PLK6108	\$	109.99
Rear Brakes, Drums and Shoes, Defender 110 NAS, Genuine	RNK6109	\$	404.25
Rear Brakes, Drums and Shoes, Defender 110 NAS, Proline	PLK6109	\$	110.90

8. Bleed Screw

Defender, Range Rover Classic, Discovery I, Genuine	RNB023	\$	4.47
Range Rover P38A, Discovery II, Genuine	RND966	\$	5.59

B Brake Master Cylinder Servo Assembly

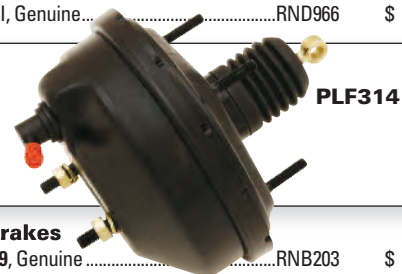

B Servo Assembly for Brakes

1. Range Rover Classic 1985-1989, Genuine			
	RNB203	\$	199.00
Defender all Models up to 1991, ProLine	PLD293	\$	199.00
Defender all Models w/out ABS 1991 on, ProLine	PLH911	\$	139.00
Defender all Models with ABS 1999 on, Genuine	RNI170	\$	364.00
Series IIA-III, 2.25 Petrol, Genuine	RNF314	\$	398.80
Series IIA-III, 2.25 Petrol, ProLine	PLF314	\$	158.20
2. Series IIA-III, Vacuum Hose, Genuine			
	RNI718	\$	3.60

C

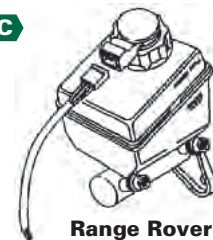

Range Rover Classic 1988-1989 PLB180



Defender 90 1994-1997 PLF285

C Brake Master Cylinders

Defender 90 1994 - 1997, Genuine	RNF285	\$	276.95
Defender 90 1994 - 1997, ProLine	PLF285	\$	129.00
Discovery I 1995 - 1999 with ABS, ProLine	PLB200	\$	245.29
Discovery II 1999 - 2004 with ABS, ProLine	PLD999	\$	299.00
Range Rover Classic 1988-1989, Non-ABS, ProLine	PLB180	\$	199.00
Range Rover P38A, Genuine	RNH682	\$	980.00



Cooling - Range Rover Classic, Discovery I



Range Rover Classic (1987-1995)



Range Rover Classic Radiator Hose Kits

Kits Include: Top and bottom radiator hoses, manifold jacket hoses, and all necessary clamps.

- 1989, Genuine **RNK1612 \$ 129.00**
- 3.9L 1990-'94, Genuine **RNK1613 \$ 149.00**
- 4.2L 1993-'94, Genuine **RNK1614 \$ 179.95**
- 4.2L 1995, Genuine **RNK1617 \$ 159.00**

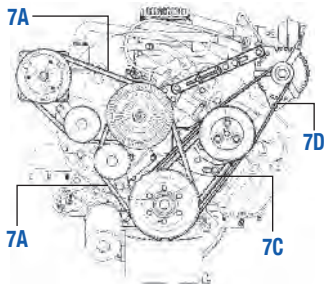

Range Rover Classic 1993-'94
Discovery I 1994



Discovery I (1994-1999)



Discovery I Radiator Hose Kits

Kits Include: Top and bottom radiator hoses, manifold jacket hoses, and all necessary clamps.

- Discovery I, Genuine **RNK1616 \$ 169.00**
- Discovery I w/EVAP Loss System, Genuine **RNK1618 \$ 189.00**

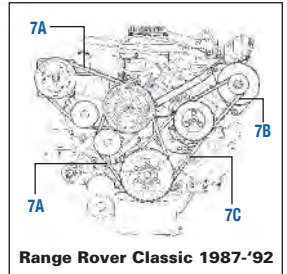
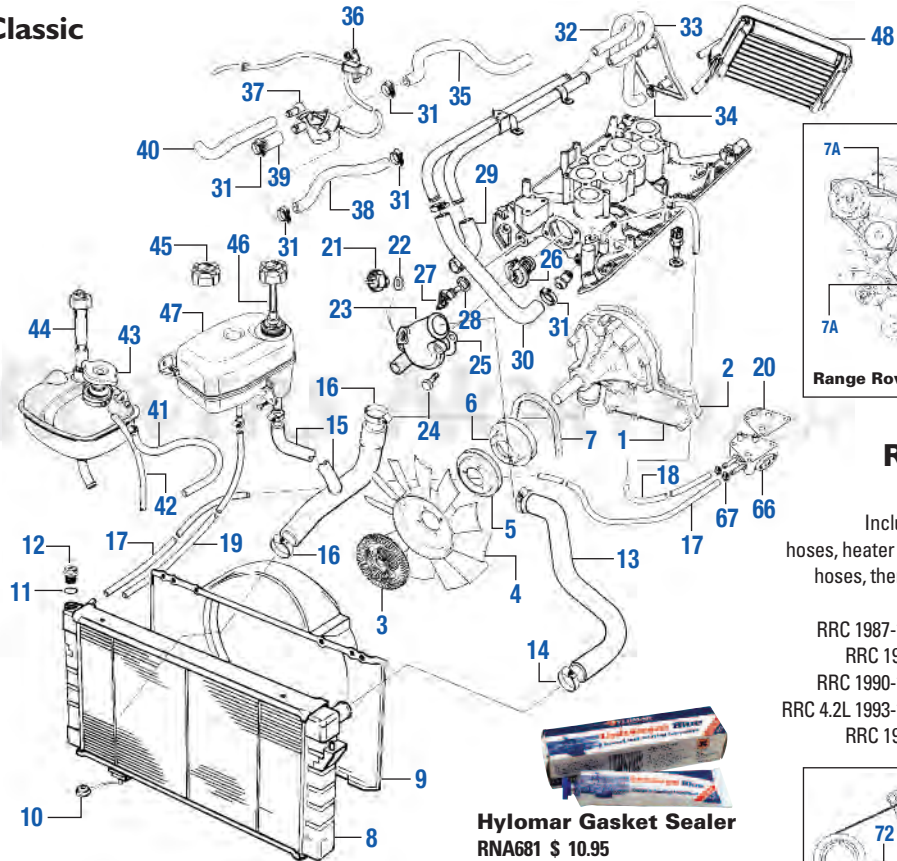

Range Rover Classic 1987-'92

RRC Cooling System Kits

Includes: Genuine radiator hoses, heater hoses, expansion tank hoses, thermostat, gasket and all necessary clamps.

- RRC 1987-'88 **RNK1601 \$ 209.00**
- RRC 1989 **RNK1602 \$ 241.45**
- RRC 1990-'94 **RNK1603 \$ 299.00**
- RRC 4.2L 1993-'94 **RNK1604 \$ 272.95**
- RRC 1995 **RNK1608 \$ 249.00**



Hylomar Gasket Sealer
RNA681 \$ 10.95

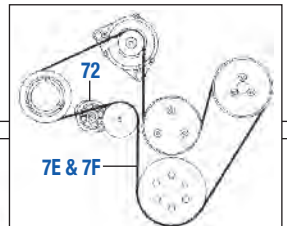

Range Rover Classic 1995,
Discovery I 1995-'99

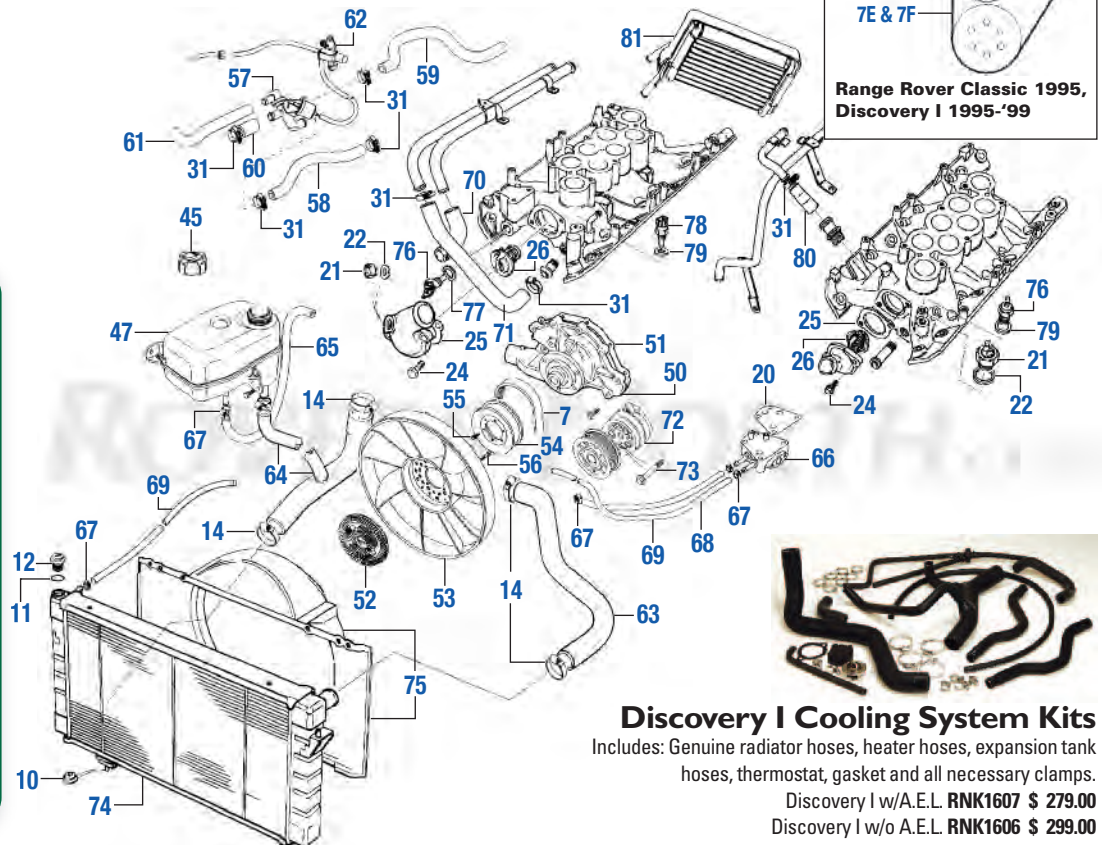

Discovery I Cooling System Kits

Includes: Genuine radiator hoses, heater hoses, expansion tank hoses, thermostat, gasket and all necessary clamps.

- Discovery I w/A.E.L. **RNK1607 \$ 279.00**
- Discovery I w/o A.E.L. **RNK1606 \$ 299.00**



Cooling - Range Rover Classic, Discovery I



1. Water Pump with Gasket , Range Rover, 1987-'94.....RNC011	\$ 239.95	29. Hose , Water Pump to Heater, 3.5 ltr/3.9 ltr/4.2 ltr.....RNC048	\$ 18.95
Water Pump with Gasket, Range Rover, 1987-'94 ProLine.....PLC011	\$ 89.00	30. Hose , Manifold to Heater Pipe, RR, 1987-'94.....RNC043	\$ 28.95
Water Pump with Gasket, Range Rover, 1995.....RNC052	\$ 289.00	Hose, Manifold to Heater, Range Rover, 1995.....RNC056	\$ 9.19
Water Pump with Gasket, Range Rover, 1995, ProLine.....PLC052	\$ 89.50	31. Hose Clamp , 3.9 ltr.....RNC049	\$ 2.61
2. Gasket , Water Pump, Range Rover, 1987-'94.....RNC012	\$ 10.31	32. Heater Inlet Hose , Range Rover, 1987-'95.....RNC021	\$ 24.30
Gasket, Water Pump, Range Rover, 1995.....RNC053	\$ 10.86	33. Heater Outlet Hose , Range Rover, 1987-'95.....RNC025	\$ 22.95
3. Viscous Fan Clutch , Range Rover, 1987-'94.....RNC018	\$ 357.61	34. Hose Clamp , 3.9 ltr.....RNC049	\$ 2.61
Viscous Fan Clutch, Range Rover, 1987-'94.....PLC018	\$ 149.95	35. Hose , Valve to Heater (from RA ->), 1994 - on.....RNC033	\$ 11.95
Viscous Fan Clutch, Range Rover, 1995.....RNC054	\$ 287.37	36. Vacuum Solenoid (from RA ->), 1994 - on.....RNC037	\$ 39.42
Viscous Fan Clutch, Range Rover, 1995.....PLC054	\$ 139.95	37. Heater Valve (from RA ->), 1994 - on.....RNC024	\$ 48.60
4. Fan , 11 Blade, Range Rover 1987-'94, 1995 RRC #53.....RNC031	\$ 151.36	38. Hose , Heater to Valve (from RA ->), 1994 - on.....RNC029	\$ 9.19
5. Pulley , Water Pump to A/C Compressor, 1987-'94, '95 RRC #54.....RNC328	\$ 129.95	39. Hose , Engine to Valve (from RA ->), 1994 - on.....RNC030	\$ 3.23
Pulley, Water Pump to Crankshaft.....RND329	\$ 87.95	40. Hose , Valve to Engine (from RA ->), 1994 - on.....RNC038	\$ 6.43
7A. A/C Pump Belt , 1987-'94, Genuine.....RNC001	\$ 17.19	41. Hose , Tank, to Radiator, 1987-'88.....RNC032	\$ 11.59
A/C Pump Belt, 1987-'94, ProLine.....PLC001	\$ 13.60	42. Bleed off Hose , 1987-'89.....RNC009	\$ 5.95
7B. Alternator Belt , 1987-'92.....RNC002	\$ 9.75	43. Filler Cap , 1988-'89.....RNC022	\$ 7.03
Alternator Belt, 1993-'94.....RNC003	\$ 34.95	44. Low Coolant Level SensorRNE802	\$ 56.18
7C. Power Steering Belt , 1987-'94, Genuine.....RNC004	\$ 26.68	45. Filler Cap , 1995.....RNC017	\$ 12.53
Power Steering Belt, 1987-'94, ProLine.....PLC004	\$ 6.95	46. Filler Cap with Low Coolant Sensor , 1990-'94.....RNC027	\$ 85.00
7A. Waterpump Belt , 1987-'94, Genuine.....RNC001	\$ 17.19	47. Tank , Genuine, 1990-'94.....RNC007	\$ 96.95
Waterpump Belt, 1987-'94, ProLine.....PLC001	\$ 13.60	Tank, ProLine, 1990-'94.....PLC007	\$ 38.95
7E. Serpentine Belt RRC 3.9/4.2 ltr 1995 & Disco I 3.9 ltr 1994-'95.....RNC005	\$ 39.95	48. Heater Core , 1989-'94.....PLD415	\$ 99.95
7F. Serpentine Belt Discovery I 4.0 ltr, 1996-'99.....RNC006	\$ 35.95	Heater Core, 1995.....RND436	\$ 195.75
8. Radiator , Range Rover, 1987-'88, Genuine.....RNC020	\$ 719.97	50. Water Pump , Discovery I w/Gasket, Genuine.....RNC052	\$ 289.00
Radiator, Range Rover, ProLine, 1987-'88.....PLC020	\$ 459.00	Water Pump, Discovery I w/Gasket, ProLine.....PLC052	\$ 89.50
Radiator, Range Rover, 1989-'92.....RNC019	\$ 1402.24	51. Gasket , Water Pump.....RNC053	\$ 10.86
Radiator, Range Rover, ProLine, 1989-'92.....PLC019A	\$ 679.95	52. Viscous Fan Clutch , Discovery I, Genuine.....RNC054	\$ 287.37
Radiator, Range Rover, 1993-'95.....RNC062	\$ 699.00	Viscous Fan Clutch, Discovery I, ProLine.....PLC054	\$ 139.95
9. Cowling , Fan, 1987-'89.....RND526	\$ 51.86	53. Fan , 9 Blade, Discovery I & 1995 RRC.....RNC042	\$ 96.66
Cowling, Fan, 1990-'92.....RND527	\$ 19.95	54. Pulley , Fan/Water Pump, Discovery I & '95 RRC.....RND356	\$ 159.95
Cowling, Fan, Upper, 1993-'95.....RNE126	\$ 119.95	55. Bolt for PulleyRND551	\$ 1.45
Cowling, Fan, Lower, 1993-'95.....RND377	\$ 32.30	56. Bolt for PulleyRND552	\$ 5.88
10. Radiator Mount BushingRNC471	\$ 0.92	57. Heater Valve , up to RA104738.....RNC024	\$ 48.60
11. O-Ring for Radiator Bleed Screw.....RNC996	\$ 1.95	58. Hose , Heater to Valve, up to RA104738.....RNC029	\$ 9.19
12. Radiator Filler PlugRNC997	\$ 2.30	Hose, Heater to Valve, from RA104738, up to TA.....RND379	\$ 10.50
13. Upper Radiator Hose , Range Rover 4.2 ltr to RA647649, ProLine...PLH999	\$ 51.45	Hose, Heater to Valve, from TA.....RND380	\$ 11.84
Upper Radiator Hose, Range Rover, 3.5/3.9 ltr, 4.2 ltr		59. Hose , Valve to Heater, up to RA104738.....RNC033	\$ 11.95
from SA647650, Genuine.....RNC044	\$ 32.39	60. Hose , Engine to Valve, only, up to RA104738, Valve &	
Upper Radiator Hose, Range Rover, 3.5/3.9 ltr, 4.2 ltr		associated pipes deleted from this point.....RNC030	\$ 3.23
from SA647650, ProLine.....PLC044	\$ 11.29	61. Hose , Valve to Engine, up to RA104738.....RNC056	\$ 9.19
14. Hose Clamp for Upper Radiator Hose.....RNC013	\$ 2.80	62. Vacuum Solenoid , only, up to RA104738, Valve &	
15. Bottom Hose , Range Rover Classic, 1987-'88, Genuine.....RNC050	\$ 28.06	associated pipes deleted from this point.....RNC037	\$ 39.42
Bottom Hose, Range Rover Classic, 1987-'88, ProLine.....PLC050	\$ 10.24	63. Top Radiator Hose , Genuine.....RNC044	\$ 32.39
Bottom Hose, Range Rover Classic, 1989, Genuine.....RNC051	\$ 29.90	Top Radiator Hose, ProLine.....PLC044	\$ 11.29
Bottom Hose, Range Rover Classic, 1989, ProLine.....PLC051	\$ 19.50	64. Bottom Radiator Hose , Discovery I.....RNH998	\$ 75.95
Bottom Hose, Range Rover Classic, 1990-'94, Genuine.....RNC008	\$ 59.35	65. Small Bleed Hose off Tank , Discovery I, thru '95.....RNC014	\$ 33.29
Bottom Hose, Range Rover Classic, 1990-'94, ProLine.....PLC008	\$ 19.95	Small Bleed Hose off Tank, Discovery I, '96-on.....RNC016	\$ 12.37
Bottom Hose, Range Rover Classic, 1995, Genuine.....RND194	\$ 69.92	66. Jacket Cover AssemblyRND376	\$ 59.00
Bottom Hose, Range Rover Classic, 1995, ProLine.....PLD194	\$ 35.95	67. Hose ClampRNC049	\$ 2.61
16. Hose Clamp for Lower Radiator Hose.....RNC013	\$ 2.80	68. Hose , Manifold Jacket to Intake Manifold.....RNM086	\$ 15.80
17. Hose from Intake Jacket to Radiator, 3.5 ltr, Genuine.....RNM082	\$ POA	69. Hose , Radiator to Intake Jacket.....RNM079	\$ 43.95
Hose from Intake Jacket to Radiator, 3.5 ltr, ProLine.....PLM082	\$ 8.14	70. Hose , Water Pump to Heater, 3.9 ltr.....RNC048	\$ 18.95
Hose from Intake Jacket to Radiator, 3.9 ltr.....RNM079	\$ 43.95	71. Hose , Manifold to Heater Pipe, 3.9 ltr.....RNC056	\$ 9.19
18. Hose from Intake Jacket to Plenum.....RNM086	\$ 15.80	72. Serpentine Belt TensionerRND374	\$ 279.00
Hose Clamp.....RNC049	\$ 2.61	73. Bolt for TensionerRND553	\$ 3.31
19. Hose From Tank to Radiator, 1990-on.....RNC010	\$ 35.95	74. Radiator , Discovery I, Manual.....RNC060	\$ 719.97
20. GasketRNE149	\$ 1.98	Radiator, Discovery I, Auto, Genuine.....RNC062	\$ 699.00
21. Temp Switch for Fan , Genuine.....RNC045	\$ 49.95	Radiator, Discovery I, Auto, ProLine.....PLC019A	\$ 679.95
Temp Switch for Fan, ProLine.....PLC045	\$ 13.99	75. Fan Cowling , upper.....RNE126	\$ 119.95
22. Sealing Washer for Temp Switch.....RNC023	\$ 2.28	Fan Cowling, lower.....RND377	\$ 32.30
23. Housing for Thermostat, Range Rover, 1987-'95.....RNC040	\$ 74.00	76. Sensor for Temperature Gauge.....RNC036	\$ 18.50
24. Fixing Bolt for Thermostat Housing.....RNC028	\$ 1.60	77. Sealing Washer , 3.9 ltr.....RNC039	\$ 0.50
25. Gasket for Thermostat.....RNC046	\$ 2.61	78. Temperature Sensor , ECU, 3.9 ltr, Genuine.....RNM134	\$ 79.95
26. Thermostat 88°CRNC047	\$ 10.50	Temperature Sensor, ECU, 3.9 ltr, ProLine.....PLM134	\$ 14.95
27. Temp Sender , 3.5 ltr.....RNC057	\$ 36.00	79. Sealing WasherRNH032	\$ 0.56
Temp Sender, 3.9 ltr thru 1994, ProLine.....PLC035	\$ 8.95	80. Hose , Heater Feed.....RNC055	\$ 7.74
Temp Sender, 1995 RRC.....RNC036	\$ 18.50	81. Heater MatrixRND436	\$ 195.75
28. Temp Sender Sealing Washer , 3.9 ltr.....RNC039	\$ 0.50		

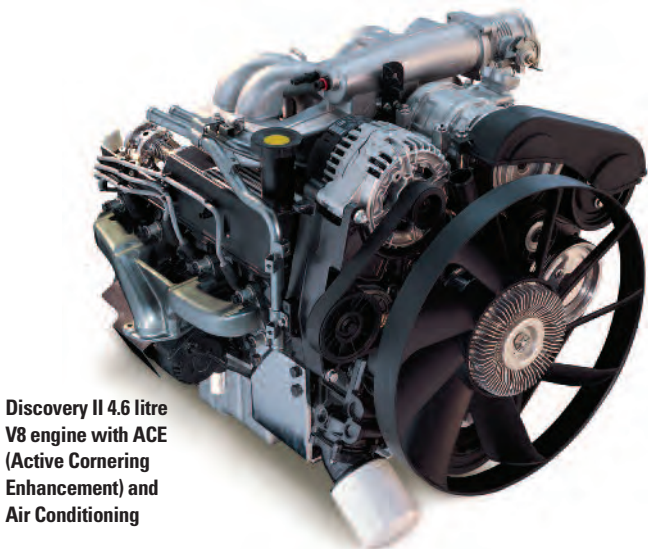
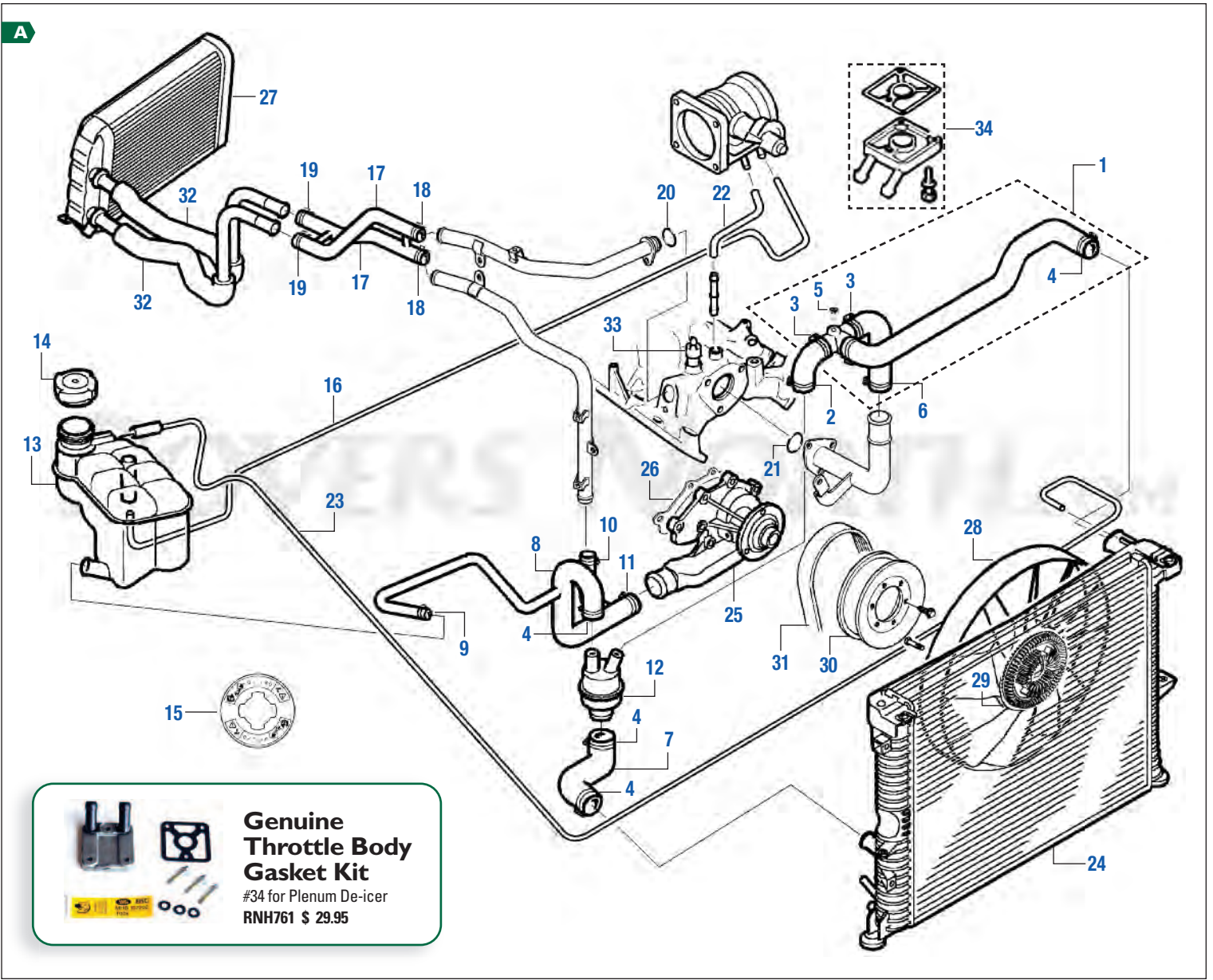

Discovery II 4.6 litre V8 engine with ACE (Active Cornering Enhancement) and Air Conditioning

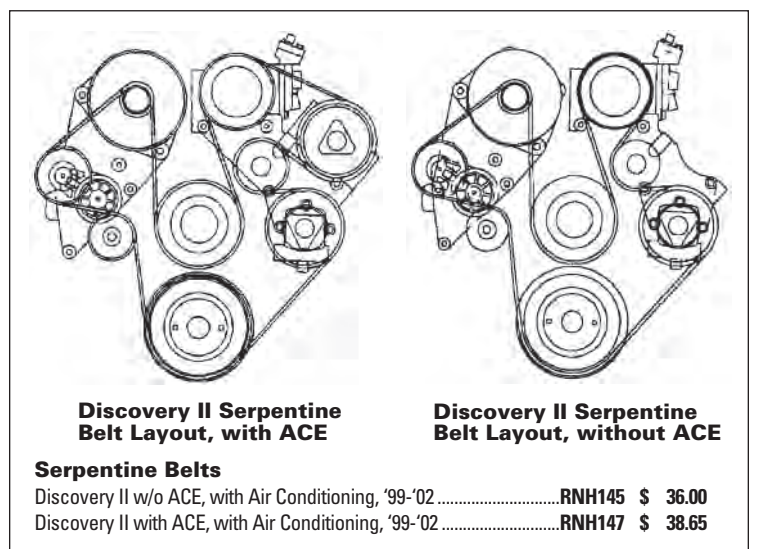



A Discovery II Cooling Parts

1. Hose Assembly, Radiator Top	RND555	\$ 55.13
2. Hose Clamp, Spring Band	RND556	\$ 1.98
3. Hose Clamp	RND557	\$ 2.99
4. Hose Clamp, Spring Band	RND558	\$ 2.99
5. Screw, Bleed	RND559	\$ 6.13
6. Hose Clamp, Spring Band	RND560	\$ 1.98
7. Hose, Radiator Bottom Coolant	RND387	\$ 15.09
8. Hose, Thermostat to Pipe Coolant	RND561	\$ 72.16
9. Hose Clamp, Spring Band	RND562	\$ 1.98
10. Hose Clamp	RND348	\$ 2.95
11. Hose Clamp	RND563	\$ 2.99
12. Housing, Thermostat, Genuine	RND564	\$ 39.91
Housing, Thermostat, ProLine.....	PLD564	\$ 28.50
13. Overflow Tank, System Expansion, Genuine	RNI554	\$ 221.10
Overflow Tank, System Expansion, ProLine.....	PLI554	\$ 59.95
14. Cap, Expansion Tank Pressure	RND344	\$ 25.90
15. Label, Coolant Warning Expansion Tank	RND565	\$ 1.12
16. Hose, Cooling System Bleed, Expansion Tank to Throttle	RND566	\$ 16.43
17. Hose Assembly, Heater In/Out	RND567	\$ 19.42
18. Hose Clamp, Flat Spring, White	RND568	\$ 7.77
19. Hose Clamp, Green	RND569	\$ 6.77
20. O-Ring	RND354	\$ 1.59
21. O-Ring	RND353	\$ 1.31
22. Hose, Manifold to Plenum De-Icer	RND514	\$ 12.98
23. Hose, Bleed Pipe Assembly	RND570	\$ 16.17
24. Radiator w/o secondary air injection, Genuine	RND494	\$ 592.08
Radiator w/secondary air injection, Genuine.....	RND495	\$ 592.08
Radiator w/secondary air injection, ProLine.....	PLD495	\$ 279.00
Cowl, Cooling System Fan, Upper.....	RND571	\$ 71.30
Cowl, Cooling System Fan, Lower.....	RND572	\$ 76.50
25. Water Pump, Genuine	RNC052	\$ 289.00
Water Pump, ProLine.....	PLC052	\$ 89.50
26. Gasket, Water Pump	RNC053	\$ 10.86
27. Heater Matrix	RND436	\$ 195.75
28. Fan, Cooling	RND388	\$ 100.04
29. Coupling, Engine Fan, Viscous	RND302	\$ 258.14
Coupling, Engine Fan, Viscous, ProLine.....	PLD302	\$ 99.79
30. Pulley, Coolant Pump	RND356	\$ 159.95
31. Serpentine Belts		
Discovery II w/o ACE, with Air Conditioning, '99-'02.....	RNH145	\$ 36.00
Discovery II with ACE, with Air Conditioning, '99-'02.....	RNH147	\$ 38.65
32. Hose Set Includes Inlet & Outlet Pipe, O-Rings, Clamps, Genuine	RNH758	\$ 103.06
33. Coolant Temperature Sensor	RNH760	\$ 26.95
34. Gasket Kit Throttle body	RNH761	\$ 29.95



Stop Leaks!

Range Rover P38A Cooling System Kits

Genuine Land Rover hoses and parts. Includes: Genuine radiator hoses, heater hoses, expansion tank hoses, thermostat, gasket and all necessary clamps.
 Cooling System Kit, Range Rover P38A up to VIN XA30701.....**RNK1610 \$ 319.95**
 Cooling System Kit, Range Rover P38A from VIN YA30702.....**RNK1610A \$ 390.00**

Range Rover P38A Radiator Hose Kits

Kits Include: Top and bottom radiator hoses, manifold jacket hoses, and all necessary clamps.
 Radiator Hose Kit, Range Rover P38A, up to VIN XA430701.....**RNK1619 \$ 199.95**
 Radiator Hose Kit, Range Rover P38A, from VIN YA430702.....**RNK1619A \$ 290.00**

Cooling System Parts

Range Rover P38A

Water Pump, Genuine	RNC052	\$ 289.00
Water Pump, ProLine.....	PLC052	\$ 89.50
Viscous Fan Clutch, P38A, Genuine	RND302	\$ 258.14
Viscous Fan Clutch, P38A, ProLine.....	PLD302	\$ 99.79
Radiator Assembly, P38A, 1995-'98, Genuine	RND357	\$ 449.17
Thermostat Assembly, P38A, Genuine	RND211	\$ 102.55
Thermostat Assembly, P38A, ProLine.....	PLD211	\$ 49.86



RNK1609



Stop Leaks!

Discovery II Cooling System Kit

Genuine Land Rover hoses and parts. Includes: Genuine radiator hoses, heater hoses, expansion tank hoses, thermostat, gasket and all necessary clamps.
Cooling System Kit, Discovery II
RNK1609 \$ 315.95

Engine Oil, Transmission Oil Cooler Lines

A



Engine Oil Cooler Lines
Range Rover Classic (1989-1994)

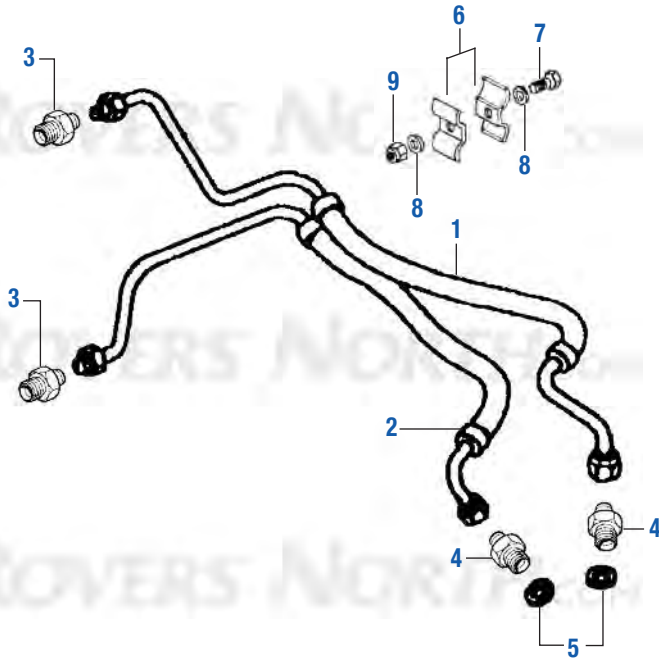

Engine Oil Cooler Lines
Discovery I (1994-1999)
Range Rover Classic (1995)

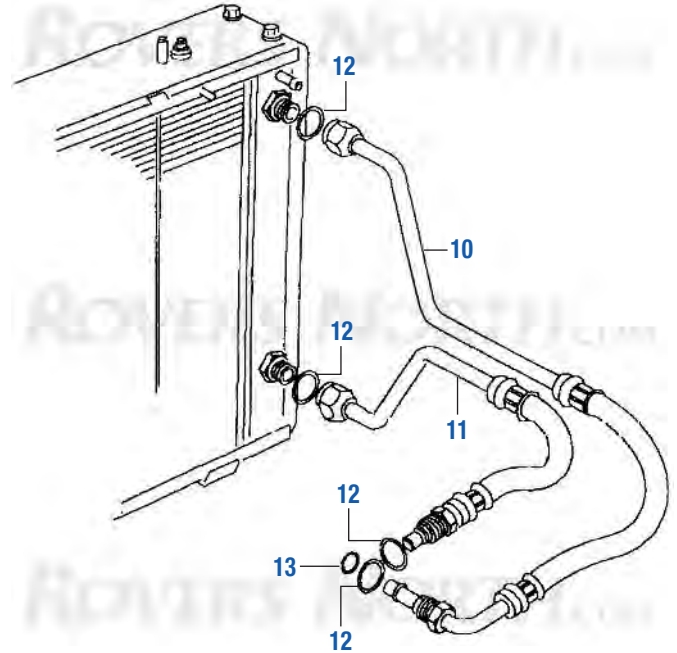

B



Transmission Oil Cooler Lines
Range Rover Classic (1989-1994)

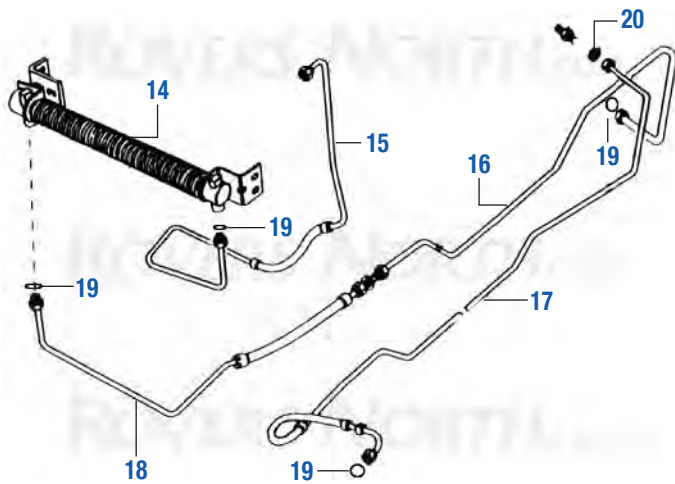

Transmission Oil Cooler Lines
Discovery Automatic (1994-1999)
Range Rover Classic (1995)

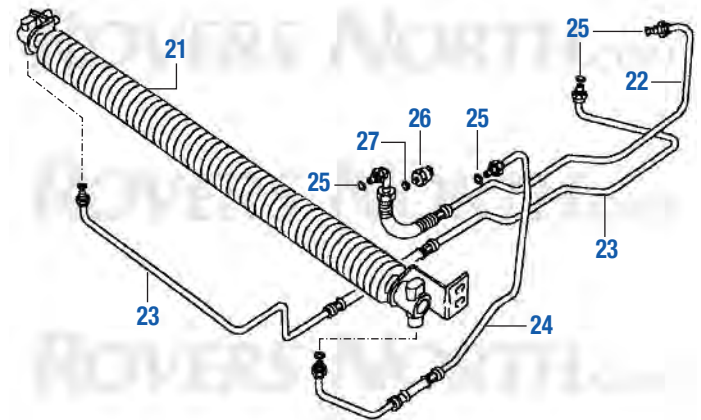

A Engine Oil Cooler Lines

Range Rover Classic 1989-'95

1. Engine Oil Cooler line (upper), 1989.....	RND330	\$ 108.10
Engine Oil Cooler line (upper), 1990.....	RND331	\$ 29.99
Engine Oil Cooler line (upper), 1991-'92.....	RND332	\$ 49.00
Engine Oil Cooler line (upper), 1993-'94.....	RND337	\$ 39.20
Engine Oil Cooler line (upper), 1995.....	RND341	\$ 119.95
2. Engine Oil Cooler line (lower), 1989.....	RND334	\$ 79.98
Engine Oil Cooler line (lower), 1990-'91.....	RND335	\$ 79.90
Engine Oil Cooler line (lower), 1992.....	RND336	\$ 49.00
Engine Oil Cooler line (lower), 1993-'94.....	RND333	\$ 45.96
Engine Oil Cooler line (lower), 1995.....	RND342	\$ 69.16
3. Adaptor cooler line to radiator 1989-'95.....	RNE460	\$ 27.07
4. Adaptor cooler line to engine 1989-'95.....	RND525	\$ 11.93
5. Sealing ring.....	RND338	\$ 2.05
6. Clamp for Oil Cooler Line.....	RNH775	\$ 2.91
7. Bolt.....	RNF533	\$ 1.59
8. Washer.....	RNX034	\$ 0.95
9. Nut.....	RNF731	\$ 0.95

Discovery I 1994-'99

10. Engine Oil Cooler Line (upper), 1994-'99.....	RND341	\$ 119.95
11. Engine Oil Cooler Line (lower), 1994-'99.....	RND342	\$ 69.16
12. O-Ring.....	RND340	\$ 3.19
13. O-Ring.....	RND339	\$ 2.19

B Transmission Oil Cooler Lines

Range Rover Classic 1989-1994

14. Transmission Oil Cooler Assembly, 1989-'92.....	RNH544	\$ 509.85
Transmission Oil Cooler Assembly, 1993-'94.....	RND381	\$ 389.78
15. Pipe Assembly Transmission to Cooler, 1989-'92.....	RNH545	\$ 32.50
Pipe Assembly Transmission to Cooler, 1993-'94.....	RNH770	\$ 53.85
16. Pipe Assembly Line Union to Transmission, 1989-'92.....	RNH546	\$ 108.10
Pipe Assembly Line Union to Transmission, 1993-'94.....	RNH771	\$ 25.88
17. Pipe Assembly Radiator to Transmission, 1989-'92.....	RNH547	\$ 237.88
Pipe Assembly Radiator to Transmission, 1993-'94.....	RNH772	\$ 99.95
18. Pipe Assembly Cooler to Line Union, 1989-'92.....	RNH667	\$ 32.50
Pipe Assembly Cooler to Line Union, 1993-'94.....	RNH773	\$ 58.83
19. O-Ring (supplied w/Genuine Pipe Assemblies), 1989-'94.....	RND340	\$ 3.19
20. Sealing Ring, 1989-'94.....	RNH774	\$ 8.90

Discovery I 1994-'99 / Range Rover Classic 1995

21. Oil Cooler Assembly.....	RND381	\$ 389.78
22. Pipe Assembly Radiator Lower to Transmission.....	RND382	\$ 79.22
23. Pipe Assembly Cooler to Transmission.....	RND383	\$ 102.69
24. Pipe Assembly Radiator Upper to Oil Cooler, Discovery I.....	RND554	\$ 54.02
Pipe Assembly Radiator Upper to Oil Cooler, RRC 1995.....	RNH770	\$ 53.85
25. O-Ring (supplied with pipe assemblies).....	RND340	\$ 3.19
26. Oil Temp Sender.....	RND384	\$ 34.45
27. Sealing Washer for Oil Temp Sender.....	RNA979	\$ 0.42

C Engine Oil Cooler Lines

Range Rover P38A 1995-'02

28. Engine Oil Cooler Assembly, 4.0 Ltr.....	RND537	\$ 244.94
Engine Oil Cooler Assembly, 4.6 Ltr.....	RND371	\$ 288.14
29. Pipe Assembly, 1995-'98.....	RND369	\$ 73.73
Pipe Assembly, 1999-'02.....	RND535	\$ 73.73
30. Pipe Assembly, 1995-'98.....	RND370	\$ 75.65
Pipe Assembly, 1999-'02.....	RND536	\$ 92.51

D Transmission Oil Cooler Lines

Range Rover P38A 1995-'02

31. Oil Cooler, Genuine.....	RND372	\$ 329.80
32. Oil Cooler to Transmission up to WA388112.....	RND541	\$ 68.37
Oil Cooler to Transmission up to WA388113.....	RND542	\$ 67.93
Oil Cooler to Transmission XA410482 on.....	RND543	\$ 70.65
33. Transmission to Oil Cooler up to WA410481.....	RND539	\$ 70.60
Transmission to Oil Cooler XA410482 on.....	RND543	\$ 70.65
34. O-Ring, 1995-'98.....	RND340	\$ 3.19
35. Sending Unit.....	RND538	\$ 78.50

C



Engine Oil Cooler Lines

Range Rover P38A
(1995-2002)

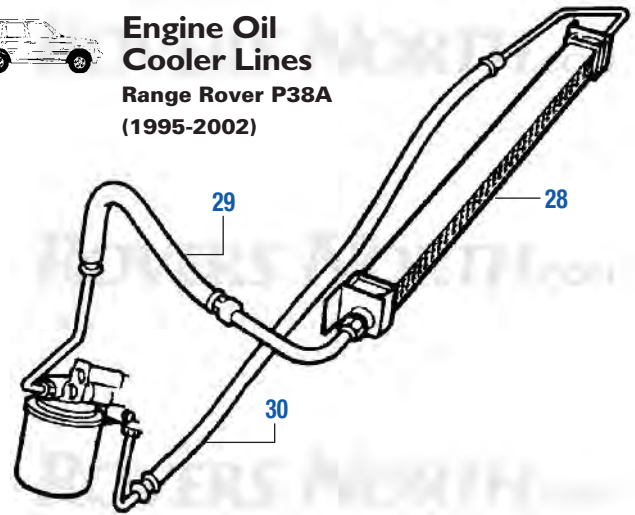

D



Transmission Oil Cooler Lines

Range Rover P38A (1995-2002)

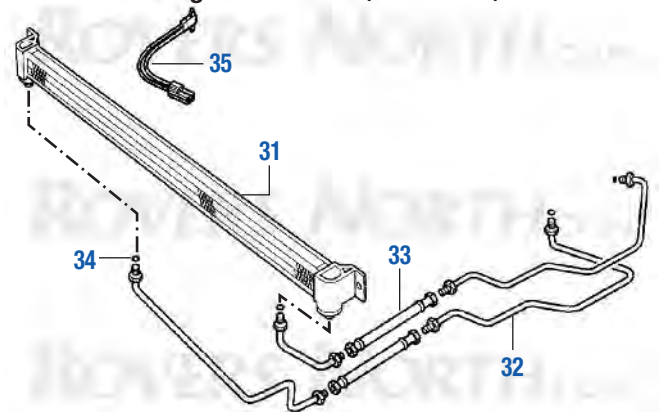

Series II, IIA, III 2.25 Litre Water Pump

ProLine



Water Pump Assembly Complete With Gasket

2.25 litre, Series IIA, III 1962 on (9 hole), Genuine.....	RNF334	\$ 129.00
2.25 litre, Series IIA, III 1962 on (9 hole), ProLine.....	PLF334	\$ 49.50
Military 2.25 litre, Series IIA, III (7 hole), ProLine.....	PLC348	\$ 89.50
2.5 litre.....	RNF361	\$ 282.47

Water Pump Rebuild Kits

2.25 litre, Series IIA, III, Genuine.....	RNE587	\$ 69.95
2.25 litre, Series IIA, III, ProLine.....	PLE587	\$ 34.95

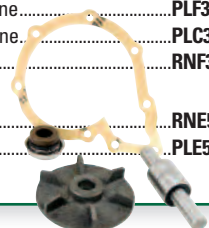



Cooling - Series II, IIA, III

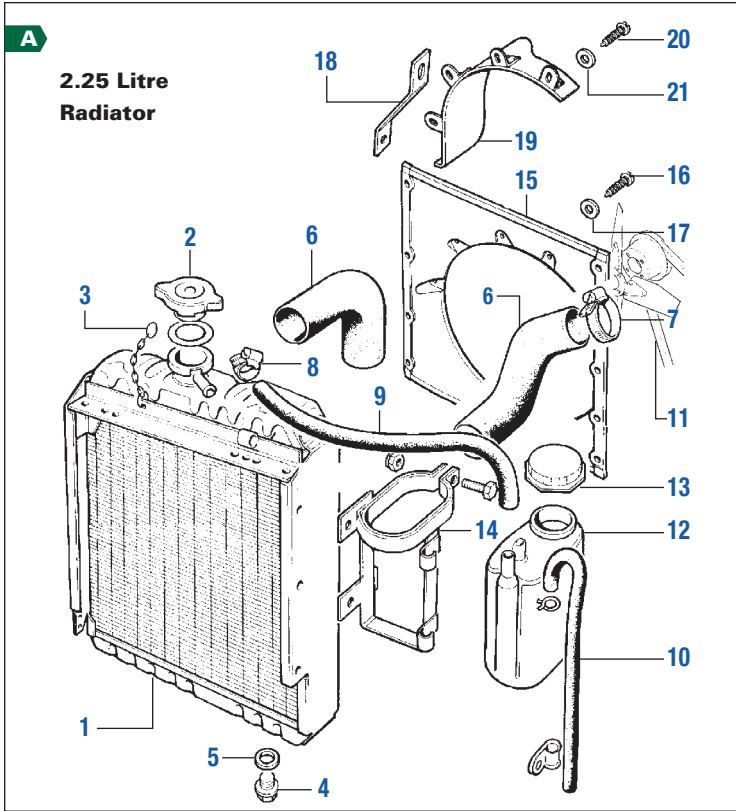

13. Cap For Overflow Tank	RNC431	\$ 7.90
14. Mounting Bracket for Overflow Tank	RNC585	\$ 29.90
15. Metal Fan Shroud, Series IIA, III 2.25 litre petrol.....	PLE447	\$ 149.50
16. Mounting Screw for Cowl, (9 required for 2.25 litre).....	RNC419	\$ 1.02
17. Spring Washer for Mounting Screw	RNF434	\$ 0.44
18. Steady Strip for Cowl, 2.25 litre, Reproduction, ProLine	PLB366	\$ 12.50
19. Metal Cowl for Fan Shroud, 2.25 Petrol, Reproduction, ProLine.....	PLC359	\$ 56.00
20. Screw for Mounting Fan Shroud	RNC795	\$ 0.64
21. Flat washer	RNF421	\$ 0.44
Radiator Shroud Kit.....	PLK159	\$ 199.00

A Radiator, Cooling Parts

1. Radiator , 2.25 litre, Series IIA, III 1970 on. Can be fitted to earlier 2.25 litre Land Rovers by fitting late type top and bottom hoses, Genuine.....	RNC513	\$ 544.47
2.25 litre, Series IIA, III 1970 on, Heavy Duty, 4 core, ProLine	PLC513	\$ 269.00
Radiator, Stage I V-8, Genuine.....	RNE428	\$ 1260.47
Radiator, 6 Cylinder.....	PLC512	\$ 469.00
2. Cap for Radiator or Expansion Tank 2.25 litre, Series IIA, 1963 on and Series III.....	RNF351	\$ 7.18
3. Chain for Radiator Cap , Series IIA, III.....	RNC186	\$ POA
4. Drain Plug for Radiator , Not required for new radiators	RNC451	\$ 8.06
5. Copper Washer for Drain Plug	RNB364	\$ 1.67
6. Radiator Hoses 2.25 litre, Series II, IIA thru 1969 Top Hose	RNC458	\$ 13.98
Middle Hose, Genuine	RNC476	\$ 3.99
Middle Hose, ProLine	PLC476	\$ 2.99
Bottom Hose	RNC459	\$ 15.93
2.25 litre, Series IIA, as shown, III 1970 on (late type) Top Hose	RNC510	\$ 29.50
Middle Hose, Genuine	RNC476	\$ 3.99
Middle Hose, ProLine	PLC476	\$ 2.99
Bottom Hose, ProLine.....	PLE407	\$ 7.30
2.25 litre, Series II, IIA thru 1969, Military Models Top Hose	RNC458	\$ 13.98
Middle Hose, Genuine	RNC476	\$ 3.99
Middle Hose, ProLine	PLC476	\$ 2.99
Bottom Hose	PLB365	\$ 24.09
2.6 litre, Series IIA, III Top Hose	RNC664	\$ 21.50
O-Ring for Water Pump	RNE561	\$ 8.76
Bottom Hose	RNC665	\$ 19.90
7. Hose Clamp for Radiator Hoses all Models	RNC013	\$ 2.80
8. Hose Clamp For Bleed Off Hose , Series IIA, III.....	RNE398	\$ 2.04
9. Bleed off Hoses , Series IIA, III 1970 on.....	RNC432	\$ 7.19
Radiator to Intake Manifold.....	RNE529	\$ 39.95
10. Drain Hose Series IIA, III, 1970 on	RNC009	\$ 5.95
11. Fan Belt , Series IIA, III, 4 cylinder	RNC422	\$ 10.44
12. Overflow Tank with cap , Series IIA, III 1970 on.....	RNC430	\$ 74.05

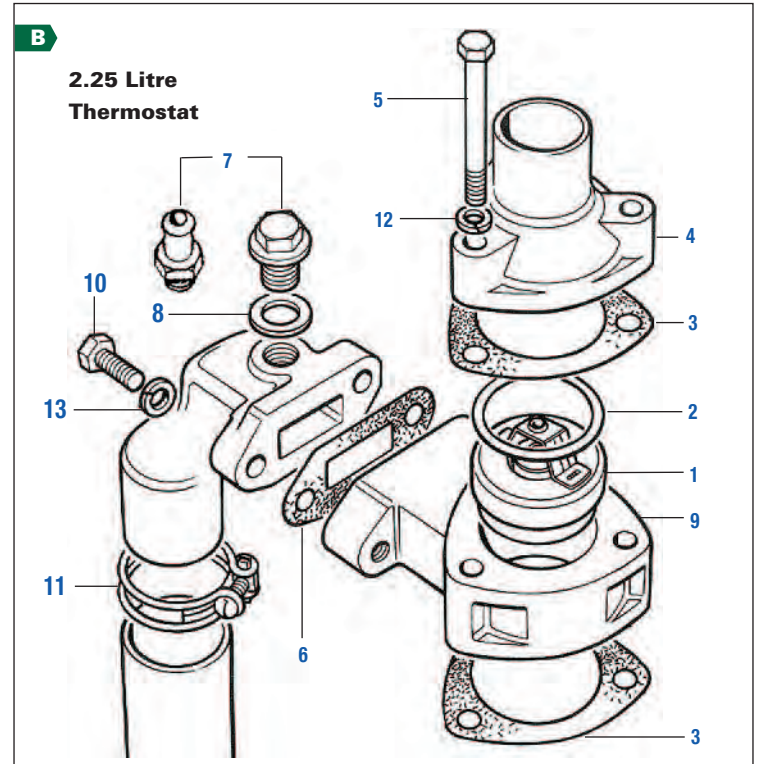

B Thermostat Housing Series Engines

1. Thermostat 2.25 litre, Series IIA, III Wax Type Thermostat, 74°C, 165°F , Genuine	RNC276	\$ 42.39
Thermostat, 74°C, 165°F, ProLine	PLC276	\$ 9.95
Thermostat, 82°C, 179°F, Genuine.....	RNC580	\$ 43.90
Thermostat, 82°C, 179°F, ProLine	PLC580	\$ 8.95
Thermostat, 88°C, 190°F, Genuine	RNC320	\$ 42.39
Thermostat, 78°C, 172°F, 2.6 litre, Genuine.....	RNC421	\$ 16.10
2. O-Ring Seal , 2.25 litre, Genuine	RNC248	\$ 1.73
3. Gaskets For Thermostat 2.25 litre Series IIA, III Top gasket, ProLine	PLC245	\$ 0.83
Bottom gasket, Genuine.....	RNB573	\$ 3.66
2.6 litre gasket, Genuine	RNB647	\$ 2.40
4. Top Housing For Thermostat , 2.25 litre.....	RNC244	\$ 69.00
5. Bolts for Thermostat Housing , (three required), Genuine	RNC907	\$ 1.10
6. By-Pass Gasket , 2.25 litre, Genuine.....	RNC738	\$ 2.78
7. Adaptor , Outlet to Heater Hose.....	RNC663	\$ 7.25
Plug	RNC289	\$ 4.60
8. Sealing Washer , Genuine.....	RNB544	\$ 1.07
9. Thermostat Housing , ProLine	PLB367	\$ 30.45
10. Thermostat Bypass Housing Bolt , Genuine.....	RNS059	\$ 1.19
11. Hose Clamp , Genuine.....	RNI756	\$ 4.56
12. Washer, Lock , Genuine.....	RNX015	\$ 0.79
13. Washer, Lock , Genuine.....	RNS037	\$ 0.59

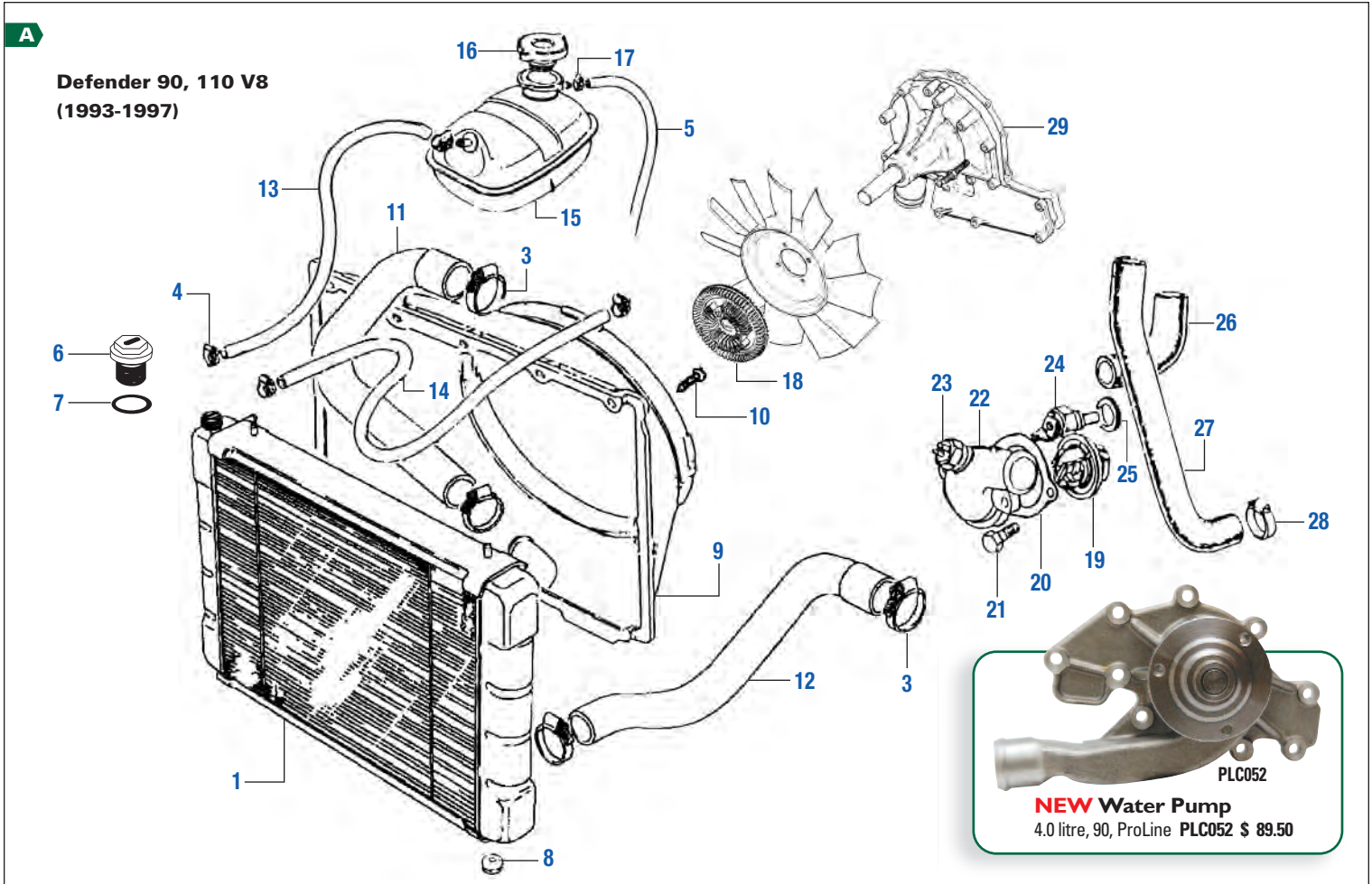

A Radiator, Cooling Parts
Defender 90, 110, 1993-'97

1. Radiator 90, 110 3.9 and 4.0 litre	RNE130	\$ 589.00
200 Tdi, Radiator, ProLine.....	PLD496	\$ 269.00
300 Tdi, Radiator, ProLine.....	PLH255	\$ 268.00
300 Tdi w/Intercooler, Genuine.....	RND500	\$ 752.47
300 Tdi w/Intercooler, ProLine.....	PLD500	\$ 498.00
Td5 W/EGR, Radiator, Genuine	RNH256	\$ 570.61
Oil Cooler Adapter 4.0 litre.....	RNE460	\$ 27.07
2. Cap for Radiator or Expansion Tank, 3.9, 4.0 litre 90,110	RNC022	\$ 7.03
3. Hose Clamp for Radiator Hoses all Models.....	RNC013	\$ 2.80
4. Hose Clamp For Bleed Off Hose, Defender 90, 110.....	RNC944	\$ 1.35
5. Drain Hose , Series IIA, III, 90, 110, 1970 on	RNC009	\$ 5.95
6. Fill Plug	RNC997	\$ 2.30
7. Sealing Washer	RNC996	\$ 1.95
8. Rubber Mount for Radiator Bottom (2 required).....	RNC471	\$ 0.92
Rubber Mount for Radiator Top (2 required)	RNE422	\$ 2.91
9. Cowl for Radiator , 3.9 Litre, 90,110.....	RNE462	\$ 89.95
4.0 Litre Auto Top Section	RNE126	\$ 119.95
Bottom Section.....	RNE106	\$ 108.87
10. Fixing Screw for 3.9 & 4.0 Cowls	RNC419	\$ 1.02
11. Top Hose 3.9 & 4.0 Litre.....	RNE463	\$ 30.79
12. Bottom Hose , 3.9 Litre, Genuine.....	RNE459	\$ 49.59
Bottom Hose, 3.9 Litre, ProLine	PLE459	\$ 24.07
Bottom Hose, 4.0 Litre.....	RNE133	\$ 70.60
13. Hose Radiator to Expansion Tank	RNC032	\$ 11.59
14. Hose Radiator to Intake Manifold.....	RNE529	\$ 39.95
15. Expansion Tank , 3.9 Litre.....	RNH393	\$ 229.95
Expansion Tank, 4.0 Litre	RNH394	\$ 134.00
16. Radiator Cap	RNC022	\$ 7.03
17. Clamp	RNE398	\$ 2.04

18. Viscous Drive Unit , 3.9 Defender 90/110, 1993 -'95, Genuine	RND034	\$ 398.00
3.9 Defender 90/110, 1993 -'95, ProLine.....	PLD034	\$ 99.80
4.0 Defender 90/110, 1997, Genuine	RNC054	\$ 287.37
4.0 Defender 90/110, 1997, ProLine	PLC054	\$ 139.95
200 Tdi, 2.5 NA Defender.....	PLI784	\$ 79.55

Thermostat Housing and Senders 3.9 & 4.0 Litre

19. Thermostat 88°C.....	RNC047	\$ 10.50
20. Gasket for Thermostat	RNC046	\$ 2.61
21. Fixing Bolt for Thermostat.....	RNC028	\$ 1.60
22. Housing for Thermostat, 3.9 Litre	RNC040	\$ 74.00
Housing for Thermostat, 4.0 Litre	RNC041	\$ 124.32
23. Temp Switch for Fan, Genuine	RNC045	\$ 49.95
Temp Switch for Fan, ProLine.....	PLC045	\$ 13.99
Sealing Washer for Switch	RNC023	\$ 2.28
24. Temp Sender , 3.9 Litre 90.....	RNC034	\$ 39.95
Temp Sender, 3.9 Litre 110, ProLine	PLC035	\$ 8.95
Temp Sender, 4.0 Litre 90.....	RNC036	\$ 18.50
25. Sealing Washer , 3.9 Litre	RNC039	\$ 0.50
26. Hose Water Pump to Heater, 3.9 Litre.....	RNC048	\$ 18.95
27. Hose Manifold to Heater, 3.9 Litre.....	RNC043	\$ 28.95
28. Hose Clamp , 3.9 Litre	RNC049	\$ 2.61
29. Water Pump Assembly Complete With Gasket		
3.9 litre 90, 110, Genuine	RNC011	\$ 239.95
3.9 litre 90, 110, ProLine.....	PLC011	\$ 89.00
4.0 litre 90, Genuine	RNC052	\$ 289.00
4.0 litre 90, ProLine.....	PLC052	\$ 89.50
Water Pump 200 Tdi, Genuine	RNH257	\$ 249.00
Water Pump 200 Tdi, ProLine.....	PLH257	\$ 89.00
Water Pump 300 Tdi	RNH258	\$ 128.00
Water Pump Assembly TD5	RNH360	\$ 148.60



Cooling - Defender 1993-1997

B



Engine Oil Cooler Lines Defender 3.9, 4.0 ltr V8

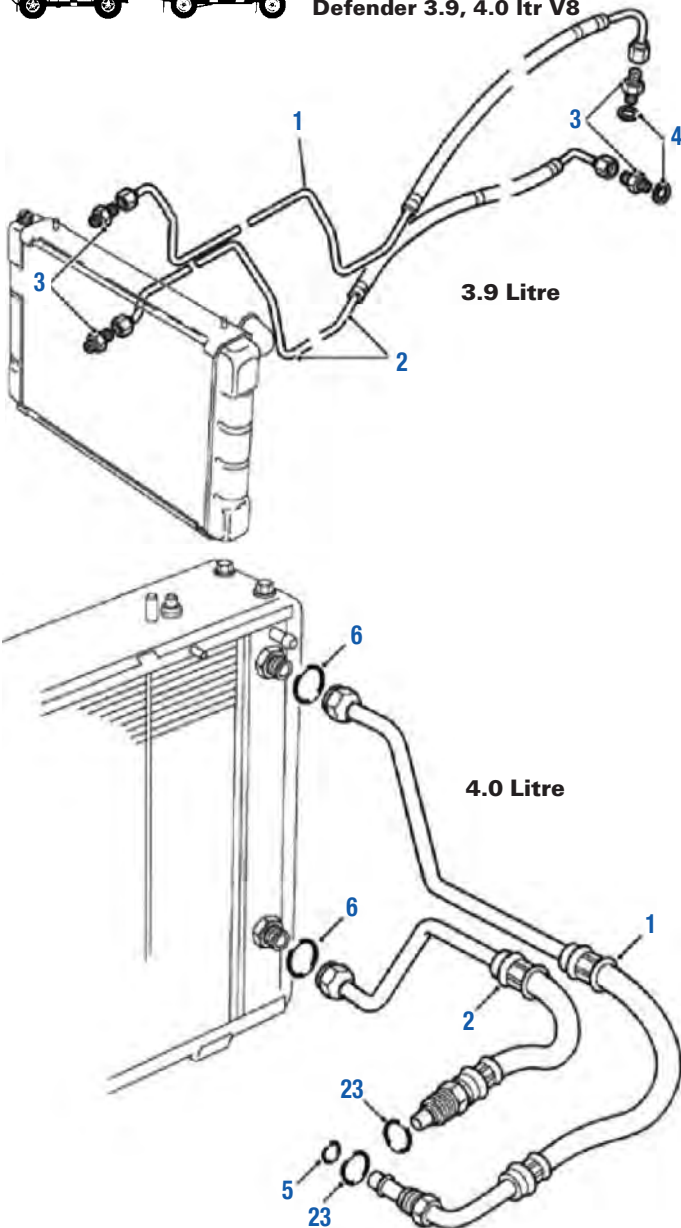

B Engine Cooler Lines

Defender 90, 110 3.9, 4.0 ltr, V8

- Oil Feed**, 110, 3.9 & 4.0 Liter, up to PA922098.....RNN227 \$ 132.56
Oil Feed 110, 3.9 & 4.0 Liter, from PA922099
Oil Feed, Defender 90, 3.9 LitreRNN228 \$ 136.09
Oil Feed, Defender 90, 4.0 LitreRND341 \$ 119.95
- Return Line**, 110, 3.9 & 4.0 Litre, up to PA22098RNN229 \$ 94.52
Return Line, 110, 3.9 & 4.0 Litre, from PA22099
Return Line, Defender 90, 3.9 LitreRNN230 \$ 132.10
Return Line, Defender 90, 4.0 LitreRND342 \$ 69.16

Oil Cooler Adapters

- Defender 110**, 3.9 & 4.0 Litre.....RNE460 \$ 27.07
Defender 90, 3.9 Litre.....RND378 \$ 7.64
Defender 90, 4.0 Litre.....RNE460 \$ 27.07
- Gasket**, Defender 110 & 90, 3.9 & 4.0 Litre.....RND338 \$ 2.05
- O-Ring Oil Cooler Line**, Defender 90, 4.0 LitreRND339 \$ 2.19
- O-Ring Oil Cooler Line, Defender 110 & 90, 4.0 LitreRND340 \$ 3.19



NEW! Defender Lamp Guards

The KBX Single Lamp Guards are easily fitted to existing 1995 on Defender NAS style tail lamps. They are supplied as a pair with stainless steel screws to allow fitting on existing NAS plinths.

Designed with style, protection & practicality in mind, the guards are manufactured in robust automotive standard ABS plastic with double wall section ribs for extra strength.

Available in Satin Black and Brunel Silver Grey, the guards are suitable to protect your lamps in style.

- Lamp Guard Pair, Defender, Satin Black.....KBX7101 \$ 39.90
Lamp Guard Pair, Defender, Brunel Silver.....KBX7401 \$ 48.99



Defender Sport Side Air Intakes

- Sports styling, strength, & improved air flow
- Quality injection moulded ABS products designed with attention to detail.
- Integral ribbed ABS mesh
- Easy to fit using stainless steel Torx head screws for added security and finish, Torx screws & Driver Bit are included.

Suitable for: (L) TD, 200 TDi, (R) 300 TDi, TD5 and TDci/Puma Defenders.

- Defender Standard, Satin Black, LH.....KBX4111L \$ 109.95
Defender Standard, Satin Black, RH.....KBX4111R \$ 109.95
Defender Premium, Brunel Silver/Java Black.....KBX4431L \$ 139.00
Defender Premium, Brunel Silver/Java Black.....KBX4431R \$ 139.00
Defender Premium, Satin Black/Brunel Silver.....KBX4121L \$ 119.95
Defender Premium, Satin Black/Brunel Silver.....KBX4121R \$ 119.95





Series Rear Round Reflector

Round reflector located on lower corners, 2.25" dia. Includes reflector, washer and nut, ProLine. **PLC357 \$ 8.95**

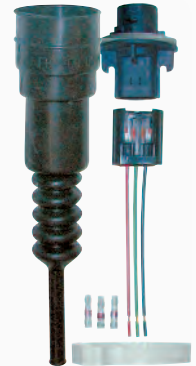

Defender Rear Light Waterproof Boot Kit

Kit includes new bulb sockets, rubber boots, clamps, connector repair kit and sealing compound. Does all five rear lamp assemblies. All components are available individually, please inquire (does not include bulb). **For Round NAS Defender Tail Lamps 1995 on, ProLineRNK9095 \$ 156.45**

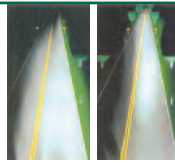

Low Beam High Beam

Hella Vision Plus Conversion Headlamp

High performance European headlamp technology - street legal D.O.T. version.

This is the most powerful, legally-approved headlamp on the market. These headlamps provide a precise, focused beam pattern that turns night into day! Single headlamp, includes 60 watt high beam / 55 watt low beam replaceable HB2 (9003) bulb and dust cover. **Fits Series, II, IIA, III, Defender 90, 110, 130, and Range Rover Classic. Sold individuallyRNC673 \$ 39.95**



Hella 60/55w HB2 (9003) bulb included!

Discovery II Rear Bumper Lamp Assemblies

Right Hand, up to VIN #2A768176, ProLine.....	PLF600	\$ 33.90
Left Hand, up to VIN #2A768176, ProLine.....	PLF601	\$ 33.90
Right Hand, from VIN #3A768177, ProLine.....	PLH683	\$ 45.00
Left Hand, from VIN #3A768177, ProLine.....	PLH684	\$ 45.00

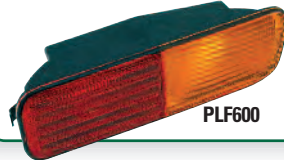

Defender NAS Lamp Assemblies

Brighten up your Defender with our Wipac Lamp assemblies. Includes mounting screws and bulb holder. Bulb not included.

1. **Stop/Tail Lamp, Red, ProLine (each).....PLC867 \$ 14.50**
2. **Directional Lamp, Amber, ProLine (each).....PLC868 \$ 14.50**
3. **Reverse Lamp, Clear, ProLine (each).....PLC869 \$ 14.50**
4. **Plinth mounting base for lamps, ProLine (each).....PLC861 \$ 6.99**
5. **Rear NAS Lamp kit**
Includes 5 plinths, 1 reverse, 2 directional, 2 stop/tail lamps.....**PLK861 \$ 99.95**

Replacement Headlight Bucket with adjuster kit

Fits Series & Defender. **WIPAC \$ 23.50**

Rear Plate Lamp Assembly

All Defender & Series models
Includes bulbs, Genuine
RNF439 \$ 17.50



Standard Issue Genuine Lamp Assemblies

Applicable to all models from Series I up to 1999 Defender. Automotive plastic construction for corrosion resistant operation. Equipped with 36-inch long wire harness with bullet end connectors. 2.75 inch diameter. Bulb not included.

1. **Stop / Tail Lamp, Red, Genuine (each).....RNF199 \$ 12.99**
2. **Directional or Park Lamp, Amber, Genuine (each).....RNF188 \$ 11.99**
Directional or Park Lamp, Amber, ProLine (each).....**PLF188 \$ 6.98**
3. **Park or Reverse Lamp, Clear, Genuine (each).....RNF187 \$ 11.99**
Park or reverse Lamp, Clear, ProLine (each).....**PLF187 \$ 7.98**
4. **Vehicle Kit, 2 park, 4 directional, 2 stop/tail lamps, Genuine.....RNK188 \$ 89.99**
5. **Bulb, Directional, 12 Volt.....RNE627 \$ 2.95**
Bulb, Stop/Tail, 12 Volt.....**RNE626 \$ 2.21**

NEW Take-Off Military Lens

Lens, Front Parking, Clear, ex-MoD
RNN222 \$ 29.99

Lens, Front Stop/Tail, Red ex-MoD
RNC784 \$ 29.99



THE STRONGEST BRUSH BAR KNOWN TO LAND ROVERS

Camel Trophy Brush Bar

Mounts to factory and Mantec bumpers. Includes lamp & limb riser mounts. Powder coated black finish.
RNA011 \$ 699.00



MANTEC

specialist vehicle equipment



Steering Guard
RNA7002 \$369.00



Wheel Carrier
RNA2550 \$499.95



Rock Sliders
RNA1001 \$399.00
RNA1005A \$422.00



Warn Winch Bumper
RNA7403 \$499.00



Raised Air Intake
RNA2002 \$298.00



Sump Alloy Guard
RNA7207 \$499.00



To see our full line of Mantec visit www.roversnorth.com/mantec

SERVICE TOOLS FOR LAND ROVERS

Rovers North Tool Roll

Perfect for any vehicle! Heavy duty canvas duck material with 25 pockets to carry a variety of tools, and two pull straps to secure roll when stowed. 14 1/4" x 27" flat size. Does not include tools shown. RNT002 \$ 29.99



Prop Shaft Socket Tool Series, Defender & Discovery

For easy front or rear prop shaft removal.....RNT141 \$ 36.50



Transmission Main Shaft Nut Tool Series II, IIA, III, 2.25 & 2.26 Litre

.....RNT0002 \$ 43.56



Hub Nut Tool Series, Defender, Discovery I & Range Rover Classic

2 1/6" for servicing the adjuster and lock nuts on your Land Rover's hub bearings.....RNF406 \$ 15.65



Drain Plug

Oil drain plug tool for slotted type drain plugs on Series differentials and gearboxes.....RNT0003 \$ 24.95



Torx Drive Bit

#40 ZF Automatic transmission oil plugs.....RNT0009 \$ 17.80
#55 R380 oil plugs.....RNT0010 \$ 39.95



Diesel Timing Tool Kit

Diesel 2.5 NA, 2.5 Turbo, 200 Tdi & 300 Tdi engines. For engine & injection pump timing adjustments. RNT2029 \$ 129.00

Viscous Fan Tool

Defender, Discovery 1994-2004 & Range Rover 1987-2002. Specialized tool for easy fan removal. 32mm & 36mm RNT140 \$ 16.90



Hand Crank for Engine Starting Series II, IIA, 4 & 6 Cylinder

Also works great as a service tool for points replacement and valve adjustment.....PLA951 \$ 26.20

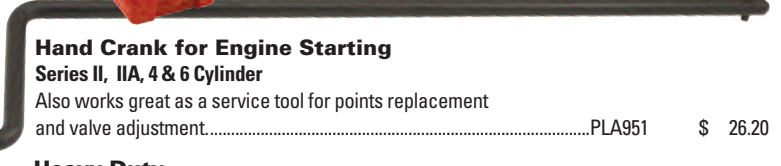

Heavy Duty Lug Wrenches Series, Defender with steel wheels.

Early Series IIA with 15/16" lugnuts.....LUG15-16 \$ 19.95
Late Series IIA, III, Defender 90, 110 with 1 1/16" lugnuts.....LUG1116 \$ 18.85



Clutch Alignment Tool

Series II, IIA, III, 2.25 & 2.26 Litre.....TLS33 \$ 5.45
Defender, Discovery V8.....TLS33D \$ 5.45



Tool Bar

For use with RNT002, RNF406 & RNT003.....RNT0004 \$ 6.18

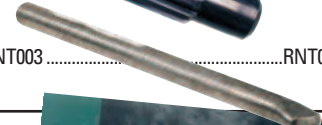

Parts Manuals, Workshop Manuals, Owners' Handbooks, Supplementary Information

With these Land Rover DVD's, you will have all the information you will need right at your fingertips.

- Parts Manual
- Workshop Manual
- Owners' Handbook
- Supplementary Information

NOTE: DVDs are compatible with Windows operating systems from 2000 through Windows 7 as well as all versions of Adobe Acrobat from version 6 through 9 (Windows 7 requires special settings, see online for details). The DVDs can also be run on Apple MAC Computers when running Windows. A virtualization software like VMware Fusion 3 or Parallels will need to be used to do this.

ORIGINAL TECHNICAL PUBLICATION DVDs

Series I, 1948-'58.....	LHP19	\$ 29.95
Series II, 1958-'61.....	LHP20	\$ 29.95
Series IIA & IIB, 1961-'71.....	LHP21	\$ 29.95
Series III, 1971-'85.....	LHP22	\$ 29.95
88 Half Ton Military, 1968-'84.....	LHP23	\$ 29.95
101 One Ton Military, 1975-'78.....	LHP24	\$ 29.95
Defender 90, 110 & XD Military, 1984-'99.....	LHP25	\$ 29.95
Defender 90, 110 & 127, 1983-'89.....	LHP26	\$ 29.95
Defender 90, 110 & 130, 1990-'98.....	LHP27	\$ 29.95
Defender 90, 110 NAS, 1993-'97.....	LHP28	\$ 29.95
Range Rover Classic, 1970-'85.....	LHP1	\$ 29.95
Range Rover Classic, 1986-'95.....	LHP2	\$ 29.95
Range Rover Classic NAS, 1987-'95.....	LHP29	\$ 29.95
Discovery I, 1989-'94.....	LHP3	\$ 29.95
Discovery I, 1994-'98.....	LHP32	\$ 29.95
Discovery I NAS, 1994-'99.....	LHP33	\$ 29.95

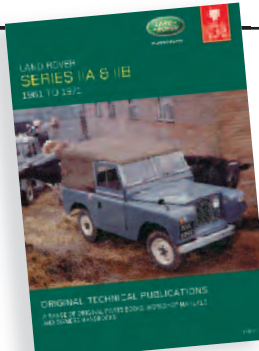

GENUINE WORKSHOP MANUALS

Discovery II, Workshop Manual RNN219 \$ 128.90
Defender 90/110 300 TDI 1996-'98, Workshop Manual RNN220 \$ 99.95
Defender 90/110 TD5 1999-'05, Workshop Manual RNI188 \$ 120.75



OFFICIAL ISSUE TO LAND ROVER, EX-MOD 109 MILITARY USER HANDBOOK

The vintage factory line drawings are unbelievable! A jewel of a book even if you don't own a military 109.....BOOK46 \$ 21.51



ROVERS

MAGAZINE

© 2011 Rovers North, Inc
1319 VT Route 128
Westford, Vermont 05494-9601, USA
Sales and Tech Support: 802.879.0032
roversnorth.com

PRSRD Std
US Postage
Paid
Permit 19
Burl., VT
05401

Land Rover Defender Sales Relief - Exploration - Peace Keeping

- New Land Rover Defenders manufactured to your requirements
- Worldwide Genuine Parts and logistic support
- Comprehensive operator and technical training programs
- Available to approved agencies and individuals operating outside the United States



Family owned by enthusiasts since 1979

ROVERS NORTH INC. 1319 VT Route 128, Westford, Vermont 05494 USA
Phone 1 802 879-0032 www.roversnorth.com Fax 1 802 879-9152

